



FAI Sporting Code

*Fédération
Aéronautique
Internationale*

Section 4 – Aeromodelling

Volume ABR Section 4A, Section 4B, Section 4C

2011 Edition

Effective 1st January 2011

SECTION 4A – CIAM INTERNAL REGULATIONS

SECTION 4B – GENERAL RULES FOR INTERNATIONAL CONTESTS

SECTION 4C – GENERAL REGULATIONS AND RULES FOR CONTESTS AND
RECORDS

*Avenue Mon-Repos 24
CH-1005 Lausanne
(Switzerland)
Tél.: +41(0) 21/345.10.70
Fax: +41(0) 21/345.10.77
E-mail: sec@fai.org
Web: www.fai.org*

FEDERATION AERONAUTIQUE INTERNATIONALE

Avenue Mon Repos 24, 1005 LAUSANNE, Switzerland

Copyright 2011

All rights reserved. Copyright in this document is owned by the Fédération Aéronautique Internationale (FAI). Any person acting on behalf of the FAI or one of its Members is hereby authorised to copy, print, and distribute this document, subject to the following conditions:

- 1. The document may be used for information only and may not be exploited for commercial purposes.**
- 2. Any copy of this document or portion thereof must include this copyright notice.**

Note that any product, process or technology described in the document may be the subject of other Intellectual Property rights reserved by the Fédération Aéronautique Internationale or other entities and is not licensed hereunder.

RIGHTS TO FAI INTERNATIONAL SPORTING EVENTS

All international sporting events organised wholly or partly under the rules of the Fédération Aéronautique Internationale (FAI) Sporting Code¹ are termed *FAI International Sporting Events*². Under the FAI Statutes³, FAI owns and controls all rights relating to FAI International Sporting Events. FAI Members⁴ shall, within their national territories⁵, enforce FAI ownership of FAI International Sporting Events and require them to be registered in the FAI Sporting Calendar⁶.

Permission and authority to exploit any rights to any commercial activity at such events, including but not limited to advertising at or for such events, use of the event name or logo for merchandising purposes and use of any sound and/or image, whether recorded electronically or otherwise or transmitted in real time, must be sought by way of prior agreement with FAI. This includes specifically all rights to the use of any material, electronic or other, that forms part of any method or system for judging, scoring, performance evaluation or information utilised in any FAI International Sporting Event⁷.

Each FAI Air Sport Commission⁸ is authorised to negotiate prior agreements on behalf of FAI with FAI Members or other entities as appropriate, of the transfer of all or parts of the rights to any FAI International Sporting Event (except World Air Games events⁹) which is organised wholly or partly under the Sporting Code section¹⁰ for which that Commission is responsible¹¹. Any such transfer of rights shall be by "Organiser Agreement"¹² as specified in the current FAI Bylaws Chapter 1, para 1.2 "Rules for Transfer of Rights to FAI International Sporting Events".

Any person or legal entity which accepts the responsibility for organising an FAI Sporting Event, whether or not by written agreement, in doing so also accepts the proprietary rights of FAI as stated above. Where no formal transfer of rights has been established, FAI retains all rights to the event. Regardless of any agreement or transfer of rights, FAI shall have, free of charge for its own archival and/or promotional use, full access to any sound and/or visual images of any FAI Sporting Event, and always reserves itself the right to have any and all parts of any event recorded, filmed and/or photographed for such use, without charge.

1 FAI Statutes, Chapter 1, para. 1.6

2 FAI Sporting Code, General Section, Chapter 3, para 3.1.3.

3 FAI Statutes, Chapter 1, para 1.8.1

4 FAI Statutes, Chapter 2, para 2.1.1; 2.4.2; 2.5.2; 2.7.2

5 FAI Bylaws, Chapter 1, para 1.2.1

6 FAI Statutes, Chapter 2, para 2.4.2.2.5

7 FAI Bylaws, Chapter 1, para 1.2.3

8 FAI Statutes, Chapter 5, para 5.1.1; 5.5; 5.6

9 FAI Sporting Code, General Section, Chapter 3, para 3.1.7

10 FAI Sporting Code, General Section, Chapter 1, paras 1.2. and 1.4

11 FAI Statutes, Chapter 5, para 5.6.3

12 FAI Bylaws, Chapter 1, para 1.2.2

PAGE DELIBERATELY LEFT BLANK

INTRODUCTION TO SPORTING CODE SECTION 4

Sporting Code Section 4 contains the rules and regulations for FAI recognised activities in model aircraft and space models. These regulations are the responsibility of the FAI Aeromodelling Commission (CIAM) and complement the General Section which contains the rules and regulations common to all FAI activities.

Section 4 is split into volumes to ease downloading the regulations for specific activities. Volume ABR gives the General Rules for CIAM activities, competitions and records that are applicable for each activity. The specific volumes contain all CIAM documents for the activity concerned: Official classes, World Cup rules, provisional classes, guides for organisers and judges. The specific activities and related volumes are shown in the table below.

ACTIVITY	VOLUME
General rules for CIAM Activities, Competitions and Records	ABR
Model Aircraft Competitions	
• Free Flight	F1
• Control Line	F2
• RC Aerobatics	F3 Aerobatics
• RC Soaring	F3 Soaring
• RC Helicopter	F3 Helicopter
• RC Pylon Racing	F3 Pylon Racing
• Scale Model Aircraft	F4
• RC Electric Powered	F5
• Promotional Classes	F6
• Aerostats	F7
Space Models	
• Space Models Competitions and Records	SM

The use of “shall” and “must” implies that the aspect concerned is mandatory. The use of “should” implies a non-mandatory recommendation; “may” implies what is permitted or what might happen, and “will” indicates what is going to happen. Words of masculine gender should be taken as including the feminine gender unless the context indicates otherwise. Italics are used for explanatory notes.

THIS 2011 EDITION INCLUDES THE FOLLOWING AMENDMENTS MADE TO THE 2010 CODE

These amendments are marked by a double line in the right margin of this edition

Paragraph	Plenary meeting approving change	Brief description of change	Change incorporated by
Page 17	n/a	Deleted erroneous "Part One" from the title.	Jo Halman Technical Secretary
A.1.3	n/a	Consequential change to cross-reference number.	
A.2.1	2010	Clarify voting at Technical Meetings.	
A.2.2		Voting now by simple majority.	
A.4.2		Add F4F to the "even year" column.	
A.6.1 g)		Delete the need for proposal hard copies ref FAI office.	
A.7.1		Clarify the time for submission of proposals; amend note.	
A.7.1, A.14.2f, B.2.6e, B.16.2, Annex B.1b		Volume paragraph re-numbering caused amended cross-references.	
A.9.1	n/a	Consequential change to cross-reference number.	
A.10	2010	New A.10 for sanction fees.	
A.10 – A.17		Re-numbered to A.11 – A.18	
A.11 & A.12		Amended to reflect changes status & new submission procedure.	
A.13		Replace the first paragraph and amend the fourth paragraph.	
A.14.1		Amended reference to the new A.10.	
A.14.2	n/a	Clarified for transport.	
A.15.2 & A.16.2	n/a	Consequential change to cross-reference number.	
A.18	2010	Clarified conditions for the Selection Group.	
Annex A.2a		Amended in line with new A.10.	
Annexes A.2c, A.2d & A.2e	n/a	Consolidated into a single page.	
Annex A.2h	2010	Clarified that the diploma is for world records.	
Annex A.2i		Clarified that the diploma is for outstanding sporting achievements.	
B.2.6		Delete the restriction of only World Championship classes.	
B.2.8		Clarified aeromodelling events.	
B.2.9		List first category events	
B.3.4 a)		Clarified and expanded regarding helpers.	
B.3.5		Amended to include a junior as a 4th team member in classes that do not have separate junior championships.	
B.9.1		Second paragraph clarified champions to include juniors.	
B.11.2 – B.11.7		Paragraphs re-written.	
B.15.1a)		Change the wind strength for Control Line.	
B.16.1e, B.16.2c, B.16.3a		Consequential changes from B.3.5 amendment	
B.16.4e & B.16.4f		Change the order of medal presentation; re-numbered the sub-paragraphs as alphas...	
B.17.1		n/a	
B.17.1	2008	Delete F4B; decision 2008; effective 2011	
B.17.11	2010	Delete F3A & insert F3D.	
B.17.15		Heading to include F1E.	
B.17.15 d)		Delete "minimum".	
B.21.6		New procedures for handover of CIAM perpetual trophies under new paragraphs & sub-paragraphs.	
Annex 1.1		Added F3F as an RC Championship & consequential changes from B.3.5 with re-numbered paragraphs.	
Annex 1.1	2008	Delete F4B; decision 2008; effective 2011	

The Four-Year Rolling Amendments for Reference appear overleaf.

Four-Year Rolling Amendments for Reference			
Paragraph	Plenary meeting approving change	Brief description of change	Change incorporated by
Page 11 & A.11	n/a	Consequential change ref deletion of Annexes A.2.c, A.2.d, A.2.e	Jo Halman Technical Secretary
Page 13		Added a note regarding the "Parts" of the Code.	
1.3.3 & b.17.1		F3G deleted as no rules have ever been approved	
A.2.2	2009	Add Plenary voting rules & re-number subsequent paragraphs.	
A.4.2		Clarification of the election years for S-C Chairmen.	
A.13.2, A.17		New CIAM Scholarship	
Pages 27, 28, 29	n/a	Consequential change ref deletion of Annexes A.2.c, A.2.d, A.2.e	
Annex A.1.a	2009	Championship bids to conform to CIAM naming policy.	
Annex A.1.b		Bulletin 0s as draft bulletins & to contain anti-doping statement & changes to awards.	
Annex A.1.c		Correct championship names.	
Annex A.2m		Scholarship nomination form	
Annex A.2.b	n/a	Addition of year reminder & S-C voting	
Annex A.2c, A.2d		Deleted as superseded by FAI electronic procedure	
Annex A.2e		Deleted as CIAM/FAI internal administration form only	
B.2.2		Corrected sentence – deleted "international"	
B.2.3 & B.2.4	2009	Change minimum 5 classes to 8 for Space Modelling.	
B.2.5		Add World Air Games & re-number subsequent paragraphs.	
B.2.7		Add World Air Games.	
B.3.1		Add Therapeutic Use Exemption text & re-number sub-paragraphs.	
B.3.4		Add F1D Juniors incomplete teams text.	
B.3.7		Add Therapeutic Use Exemption text.	
B.4.4		Amend Jury composition.	
B.5.2		Clarify local rule application.	
B.5.3		Add online entry usage & World Cup entry limitation & re-number subsequent paragraphs.	
B.5.5		Relocate to B.5.6 all references to competition fuel; clarify.	
B.8.7		Add facilities for anti-doping testing & re-number subsequent sub-paragraphs.	
B.9.2		Add clarification regarding F1E timekeepers.	
B.11.2		Amend text regarding RC transmitter control including spread spectrum.	
B.12		Add new paragraphs for Space Modelling organisers & re-number subsequent paragraphs B.13 to B.21	
B.17 (was B.16)		Add F3M & F3P to model aircraft processing. Delete F3A & F4 engine marking & Scale sticker requirements.	
B.16.2 (was B.15.2)		Add FAI Continental Championships team medals. Consequential change for Space Modelling team medals instead of at para B.2.4	
B.20.		Consequential changes from B.3.1 & corrected cross-reference	
B.21.6 & B.21.8		Amend Championship trophy requirements.	
1.1		Amend the Free Flight definition.	
1.3.1		Add new class F1R	
1.3.2		All F2 safety strap requirement.	

Four-year Rolling Amendments for Reference.../cont

cont/... Four-year Rolling Amendments for Reference

Four-Year Rolling Amendments for Reference			
Paragraph	Plenary meeting approving change	Brief description of change	Change incorporated by
1.4.12	n/a	Corrected the principle for Control Line	Jo Halman Technical Secretary
1.4.15		Deleted erroneous "Free Flight"	
2.2.3		Corrected cross-reference	
2.8.1	2009	Add electronic device calibration requirement.	
Table III 13.d		Add calibration certificate requirement.	
Note	n/a	<i>The changed status of F3F to official has been noted in the separate document "Current CIAM classes".</i>	
Annexes A.2c & d	n/a Revised Edition	Further refinements to enable greater accuracy of the purpose of the annexes	
Annex A.2e		Corrected to include Aerostats Subcommittee chairman	
B.15.2, B.15.2a, B.15.3		Corrected the titles for clarity & deleted erroneous "international" from text.	
1.3.3		Amended class F3I to F3Q in line with CIAM class naming policy	
Part Two Records Table 1		Added a row in the F2 section to delineate Team Race from Speed and applied an appropriate title.	
Page 5 & 1.3.7	n/a	Consequential change: Change volume to Aerostats.	
A.2.1. & A.4.5	2008	Expand the procedure at Plenary Meetings.	
A.3.1.		Clarify the wording of the composition of Bureau.	
A.6.1	n/a	Emphasises the format for submitting proposals.	
A.7.1	2008	Clarification of Plenary Agenda publication.	
A.9.1		Change from Technical Secretary to Secretary.	
A.12.		Delete the outdated note.	
Annex A.1a		Entirely re-written guide for submitting bids to host Championships.	
Annex A.1b		New guide for organiser bulletins.	
Annex A.2.a	n/a	Consequential change: re WAG events may only be held in odd years ref FAI office.	
Annex A.2b	2008	Expanded the notes for clarity.	
Annexes A.2c & d	n/a	Consequential changes: text amended to bring in line with the descriptive names of the sub-committees & with FAI office procedure wef September 2008.	
Annex A.2.e		Consequential change re A.3.1.	
B.1, B.4.4 & B.5.1		Delete obsolete reference to Section D.	
B.2.5.	2008	Add new paragraphs & amend existing text regarding World Cups.	
B.3.1		New text for unsporting behaviour & disqualification.	
B.3.2 a, b, c		Add two new paragraphs regarding FAI licences & apply a paragraph number to the existing paragraph.	
B.4.2		Amend and restructure the paragraphs regarding Contest Officials.	
B.4.6	n/a	Corrected English.	
B.5.1		Inserted missing "in".	
B.5.4		Was in conflict with the General Section. Revised text	
B.5.4.	2008	Add text for FAI "nationality" competitors. Clarify the submission of results for international competitions.	
B.6.1.		Rationalise the time-scale of bids to host Championships.	
B.7.4.		Amend the entry fee structure for Championships. Add new accommodation instructions for organisers.	
B.8.6	n/a	Corrected reference.	

Four-year Rolling Amendments for Reference.../cont

cont/... Four-year Rolling Amendments for Reference

Four-Year Rolling Amendments for Reference			
Paragraph	Plenary meeting approving change	Brief description of change	Change incorporated by
B.14.1c	2008	Amend paragraph c for F3B & F3J.	Jo Halman Technical Secretary
B.16.1	2008	Add F3K	
B.17 Note	n/a	Corrected the cross-reference.	
Annex B.1a		Corrected to exempt F4 from model identification mark & reflect change in F2C.	
Annex B.1.b		Expand and number the notes for clarification.	
Annex B.2		GBR country corrected to United Kingdom which is the member of FAI (ref FAI office).	
1.1	2008	New definition.	
1.3.3. & Annex 1.1		Replace "thermal soaring" with "multi-task" at each occurrence.	
1.4.1, 1.4.3 & 2.2.4	n/a	Delete "st" – ambiguous.	
Annex 1.1 3h & 7b	2008	Add F3K. Amend the date in the first paragraph	
2.2.1	n/a	Correct "will" to "shall" to confirm the mandatory aspect.	
2.7.4		Consequential change: delete latter part of sentence.	
Records 2.2.2.	2008	Clarify COMB power sources.	
Records 2.4.4.		Correct the cross-reference.	
Records 2.4.6	n/a	Corrected English.	
Records 2.6.1		Corrected reference.	
Records 2.7.1		Corrected the line lengths for Speed classes 131 & 132.	
Records 2.8.1.	2008	Apply paragraph numbers and substitute "altitude" for "height".	
Records 2.10		Delete whole 2.10 (autonomous flight) and renumber remaining paragraphs.	
Records 2.10.1e	n/a	Consequential change: amend reference to 2.11.	
Records 2.11		Corrected references.	
Table I	2008	Delete all F8 autonomous flight references & classes 900 to 934.	
Tables II & III		Clarify COMB power sources.	
Table III item 8		Delete reference to F8 category.	
Table III	n/a	Consequential change: amend references.	
Annex 1.1		Rationalised titles & structure.	
Throughout		Volume names rationalised.	
Annex A.2a	2007	Credit card information added & text clarified.	
A.3.2.b & A.3.2.c		Added Continental Championships.	
A.3.2.c		Added RSO to the Judges for approval by Bureau.	
A.3.4		Entirely new text relating to the Assistant Secretary.	
A.3.7, A.3.7.1, A.3.7.2		Added new paragraphs for publication of safety notices & rules.	
A.6.1.a	n/a	Corrected the English regarding proposals.	
A.9.1	2007	Amended the structure & added text about fee payment.	
Annex A.2a	n/a	Competition registration form amended to include credit card payments.	
B.4.3.		Corrected type of Championship to Continental	

Four-year Rolling Amendments for Reference.../cont

Four-Year Rolling Amendments for Reference			
Paragraph	Plenary meeting approving change	Brief description of change	Change incorporated by
A.6.1.a	n/a	Corrected the English regarding proposals.	Jo Halman Technical Secretary
A.9.1	2007	Amended the structure & added text about fee payment.	
Annex A.2a	n/a	Competition registration form amended to include credit card payments.	
B.4.3.		Corrected type of Championship to Continental	
B.5.1	2007	Organisation – added title.	
B.5.2		Local Rules – re-numbered from B.5.3.	
B.5.3		Entry Forms – new paragraph with title and some text moved from B.6.1 plus new text.	
B.5.4		Results – re-numbered from B.6.5, added title, and 'organiser' corrected to 'co-ordinator'.	
B.6		Organisation of WCh & ECh – re-numbered from B.5.2 and expanded title.	
B.6.1		Re-numbered from B.5.5, amended title and clarified bid content.	
B.7		Contest Information & Entry Fees - re-numbered from B.6.	
B.8 – B.20		Re-numbered from B.7 – B.19	
B.7.1		Information - re-numbered from B.6.1, added title and amended text to clarify Bulletin requirements.	
B.7.2		Entry Fees - re-numbered from B.6.2, added title and amended text for clarity.	
B.7.3		Sponsorship - re-numbered from B.6.3, added title and corrected the English.	
B.7.4		Additional Fees - re-numbered from B.6.4. Added title and amended the text to better define accommodation standards and Bulletin 0 information.	
B.8.4		Deleted the reference to F1A-B-C flying schedule (was B.7.4).	
B.9.1		More clearly define starting positions and moving thereof. Add new text regarding test flying. For F1E, clarify from where the competitor may launch his aircraft (was B.8.1).	
B.15.1	n/a	Correction to e) to contain two paragraphs and delete f)	
B.16	2007	Exempt Indoor models from the need for FAI stickers.	
1.2		Add turbine thrust limitation and exempt turbines from noise limitations.	
2.2.7	n/a	Changed "alighting" to "landing"	
B.4.1, B.14.13, B.16.12, B.19.2, Annex B.1.b, Records 2.2.15 & Table III items 11, 12 & 14	2007	Consequential paragraph reference changes.	
A.12	2006	Amended period for Effective Date of Rule Changes.	
A.14		New paragraph in Provisional to Official Rules.	
A.15		New paragraph in eligibility for Championships.	
Annex A.1		Awards to include CIAM medals at Continental Championships.	

Four-Year Rolling Amendments for Reference				
Paragraph	Plenary meeting approving change	Brief description of change	Change incorporated by	
Annex A.2.a	n/a	New IBAN code for bank payments to FAI & corrected fax number.	FAI Secretariat	
Annex A.2b		Clarified example completion of a Sporting Code proposal.		
Annex A.2e	2006	Change "French Speaking" to "Assistant" Secretary.	Jo Halman Technical Secretary	
B.2.3 & B.2.4		New paragraph: number of classes at Championships.		
B.3.4	n/a	Correction: to include Continental as intended.		
B.4.1		Correction: insertion of missing words "in that order".		
B.6.1		Correction 2nd para: amend date of birth for Juniors only.		
B.7.9		Consequential: addition of electronic timing systems.		
B.11		Correction: amend paragraph to show that all B.11 applies only to Free Flight & Space Modelling.		
B.11.1		Corrections: grammatical.		
B.13.1		2006		Amend paragraph e, Interruption of the Contest.
B.14.1	Amended paragraphs a, b, d & delete e.			
B.14.2	Amended paragraph b and new c, d.			
B.14.3	n/a	Correction: Insertion of the missing title.		
B.15.6	n/a	Consequential: amended wording to reflect the new specification card & sticker.		
B.15.8	2006	Amend Processing Aircraft to follow Code conventions.		
B.15.9		Replace whole paragraph: Indoor aircraft.		
Throughout	n/a	Correction: replace instances of "he/she" to "he".		
Annexes B.1a & b		Amended design of model specification card and model sticker showing sample completion by a competitor.		
Annex B.2		Serbia and Montenegro now with separate national identification marks.		
1.3.3		Correction: list of classes: insertion of missing F3N Helicopter.		
1.4.14		Deleted "like a hoax".		
1.4.16		Changed sentence structure and added "overleaf".		
1.4.16		Deleted erroneous "9/78" figure.		
Throughout		Corrected table references & titles to Roman numerals.		
2.2.1		Corrected item reference from "item 2" to "item 3".		
2.2.2.		Corrected class from "30" to "135".		
2.2.5 & 2.2.6		2006		New paragraphs for F3 & F5 records
2.4.2				Amendment: to allow maps or WGS84 software for distance measurement
2.4.4.		n/a		Consequential change reference from "2.2.6" to "2.2.7"
2.7.1	Added the paragraph number			
2.10	2006	New section for Autonomous Flight Records F8.		
2.11.1.d		New paragraph to require NAC national record certification.		
2.8.1	n/a	Corrected paragraph indentation to follow section conventions; moved "must give" to the next paragraph.		
2.12 (7th para)		Consequential change reference 2.2.11 to 2.2.13.		
Part 2, Table I	2006	Classes 83 & 90: Insert missing asterisk & clause.		

Four-Year Rolling Amendments for Reference			
Paragraph	Plenary meeting approving change	Brief description of change	Change incorporated by
Part 2, Table II	n/a	End of item 7b & 8: deleted double bars left over from previous year changes.	Jo Halman Technical Secretary
Part 2, Table III		Consequential changes: various paragraph references.	
Part 2, Table III	2006	New item 7c: confirmation of national record.	
Part 2, Table III		New item 8: RC confirmation of new paras 2.2.5 & 2.2.6.	
Part 2, Table III	n/a	Consequential re-numbering of the subsequent paras from old item 8.	
Part 2, Table III		Changed the order of the category sections to follow the order of those categories in Part 2 with item re-numbering as appropriate.	
Part 2, Table III		Consequential change to item 14: added WGS84.	
Part 2, Table III		Clarified item 14c.	
Part 2, Table III		Consequential change to item 16, 17, 19 added electronic timing device.	

VOLUME ABR

GENERAL RULES FOR CIAM ACTIVITIES

SECTION 4A – CIAM INTERNAL REGULATIONS

- A.1. CIAM Plenary Meeting
 - A.2. Procedure for CIAM Plenary Meeting
 - A.3. Bureau
 - A.4. Sub-committees
 - A.5. Forms of Sub-committee Work
 - A.6. Proposals Submitted to the CIAM
 - A.7. Timetables for Reports and Proposals
 - A.8. Languages
 - A.9. Contest Calendar
 - A.10. Sanction Fees
 - A.11. Judges List
 - A.12. List of Technical Experts
 - A.13. Effective Date of Rule Changes
 - A.14. Aeromodelling Fund
 - A.15. Changing from Provisional to Official Rules
 - A.16. Eligibility for World Championships
 - A.17. National Rules
 - A.18. Aeromodelling Scholarship
 - Annex A.1a Guide for Submitting World and Continental Championship Proposals to CIAM for Approval
 - Annex A.1b Guide for Submitting World and Continental Championship Bulletin 0 to CIAM Bureau for Approval
 - Annex A.1c CIAM Policy for Naming of Championships
 - Annex A.2 – Forms:
 - Annex A.2a Contest Registration
 - Annex A.2b Example of CIAM Proposal
 - Annex A.2c Deleted
 - Annex A.2d Deleted
 - Annex A.2e Deleted
 - Annex A.2f-k Nominations for CIAM Awards and Diplomas
 - Annex A.2m Nomination for CIAM Scholarships
- Note: "l" is not used in the Annex numbering*

SECTION 4B – GENERAL RULES FOR INTERNATIONAL CONTESTS

- B.1. General Definition for International Contests
- B.2. Types of International Contests
- B.3. Competitors and Teams
- B.4. Contest Officials

cont/...

- B.5. Organisation of International Contests
- B.6. Organisation Specific to World and Continental Championships
- B.7. Contest Information and Entry Fees for World & Continental Championships
- B.8. Special Contest Organisation Requirements
- B.9. Free Flight
- B.10. Control Line
- B.11. Radio Control
- B.12. Space Models
- B.13. Timing
- B.14. Duration of a Contest
- B.15. Interruption of the Contest
- B.16. Classification and Awards at World and Continental Championships
- B.17. Processing of Model Aircraft
- B.18. Protests
- B.19. Safety Precautions and Instructions
- B.20. Disqualification from the Contest
- B.21. FAI Championship Trophies
- Annex B.1.a - Sample FAI Model Specification Certification
- Annex B.1.b - FAI Sticker
- Annex B.2 - Aircraft Nationality and Registration Marks
- Annex B.3 - General Organisation of a World Championship

SECTION 4C – MODEL AIRCRAFT

General Regulations and Rules for Contest and Records

PART ONE – GENERAL REGULATIONS FOR MODEL AIRCRAFT

- 1.1. General Definition of Model Aircraft
- 1.2. General Characteristics of Model Aircraft
- 1.3. Classification of Model aircraft
- 1.4. Definitions of the Expressions used for Model Aircraft Specifications and Rules

Annex 1.1 World Championship Events for Model Aircraft

PART TWO – RECORDS

- 2.1. World Class Records
- 2.2. General Specifications of Model aircraft for Record Attempts
- 2.3. Special Rules for Duration Records
- 2.4. Special Rules for Distance Records in a Straight Line
- 2.5. Special Rules for Speed Records in a Straight Line
- 2.6. Special Rules for Speed Records in a Closed Circuit

cont/...

2.7. Special Rules for Speed Records in Circular Flight

2.8. Special Rules for Altitude Records

2.9. Special Rules for Distance in Closed Circuit records

2.10. Dossier of a Record Attempt

2.11. Supporting Data

Table I Classification of records

Table II Application for record attempt confirmation – model aircraft

Table III Record dossier check form - model aircraft

Note: The following Parts refer to the separate volumes:

Part Three – Free Flight

Part Four – Control Line

Part Five – Radio Control

Part Six – Scale

VOLUME ABR

SECTION 4A

CIAM INTERNAL REGULATIONS

A.1. CIAM PLENARY MEETING

- A.1.1. The Plenary Meeting of the CIAM shall convene once a year in March or at such other times as shall be decided by the President of the CIAM. The meeting will be held at the FAI in Lausanne, if no special advantages are to be found elsewhere, subject to the approval of the Secretary General of FAI.
- A.1.2. The Agenda for the meeting is prepared by the CIAM Secretary in agreement with the President of the CIAM, and distributed by the FAI Office.
- A.1.3. The Agenda shall include proposals drawn up in the manner required in paragraphs A.6 and A.13. The Agenda shall be despatched to the NACs and the officers of the Bureau with the notice convening the meeting not later than 45 days before the meeting. If the Agenda is not sent out in proper time, the Plenary Meeting may be postponed by the President.

A.2 PROCEDURE FOR CIAM PLENARY MEETINGS

- A.2.1. On the first day there will be preliminary Technical Meetings held by the Chairmen of the appropriate Sub-committees. These meetings shall consider items in the agenda for the purpose of discussion and briefing of all those present and shall, through the Sub-committee Chairman, make their recommendations thereon together with the recommendations resulting from voting in the Sub-committee proper to the Plenary Meeting. Eligible to attend are Sub-committee members, voting Delegates, Alternates and any others approved by their National Airsports Controls. Among those eligible to attend, only one per country may vote.
- A.2.2. The voting system at CIAM Plenary is that of a simple majority. The votes for a proposal are counted and then the votes against the proposal are counted. The higher number of votes decides whether the proposal succeeds or fails. Abstentions do not affect the outcome and are not counted.
- A.2.3. The President may add to the Agenda, any matter considered to be urgent.
- A.2.4. The Minutes of the plenary meeting are to be drafted by the Secretary, approved by the President and distributed by the office not later than 6 weeks after the meeting.

A.3. BUREAU

- A.3.1. The Bureau is composed of a President, three Vice Presidents, a Secretary, a Technical Secretary, and a Treasurer plus the Chairmen of those Sub-Committees that have official World Championship classes as well as the Education Sub-Committee Chairman. It is completed by the immediate past President of the CIAM, who does not have voting rights. The President may also invite representatives of the NACs preparing World Championships or other persons required for the business of the Bureau.
- A.3.2. **The following matters are within the Bureau's competence:**
- a) The interpretation, application and control of CIAM decisions;
 - b) The control of organisation of World and Continental Championships;
 - c) The approval of World and Continental Championships Juries and Judges including the Range Safety Officer (RSO) at Space Modelling Championships.
 - d) The submission of proposals to the CIAM;
 - e) The accomplishment of any mission conferred on the Bureau by the CIAM.
 - f) To approve the lists of Judges and Technical Experts

cont/...

It is not in the competence of the Bureau to alter decisions taken during the Plenary meeting regarding the maximum entry fee for competitors and helpers at World and Continental Championships.

- A.3.3. The Secretary shall keep a register of the CIAM perpetual trophies and be responsible for preparing the Minutes of each meeting and sending them to the FAI office and the President within 4 weeks.

The Minutes of the December Bureau meeting shall be sent by the Secretary electronically to the Bureau members, Sub-Committee Chairmen and the FAI office no later than 15th January each year.

- A.3.4. The Assistant Secretary shall support the activities of the Secretary and Technical Secretary. In particular he shall take the Minutes of the Bureau and Plenary Meetings, contribute to the definition and formal issue of such Minutes and support or perform the activities that the Secretary delegates to him. The Assistant Secretary must not, in any case, directly approach individual members of the FAI office or Bureau, or the Sub-committee Chairmen but must work through the Secretary and the Technical Secretary.

- A.3.5. The Technical Secretary shall be responsible for maintaining the current Sporting Code Section 4 complete with amendments and additions in accordance with the decisions of the CIAM. He will also co-ordinate the work of the specialist Sub-committees as necessary. The Technical Secretary will also check the record attempt dossiers.

- A.3.6. The Bureau meets once a year in December and when convened by the President of the CIAM.

A.3.7 Publication of Emergency Safety Notices & Safety Rules

A.3.7.1 Publication of Emergency Safety Notices

- a) NACs shall be informed of any safety notice by email within five days of the end of the Plenary meeting or the agreement of a majority of the CIAM Bureau in the case of safety notices that need to be generated between Plenary meetings.
- b) Any safety notice shall appear on the CIAM homepage of the FAI website within five days of the end of the Plenary meeting or the Bureau decision to issue such a notice taken between Plenary meetings.
- c) All safety notices shall be the responsibility of the Technical Secretary who may liaise with the appropriate Sub-Committee Chairman regarding the formulation of any such notice.
- d) It will be the responsibility of the CIAM Technical Secretary, or in his absence, the CIAM Secretary, to liaise with the FAI office as necessary regarding the formal promulgation of any safety notice.

A.3.7.2 Emergency Safety Rules

- a) See A.3.7.1 a & b.
- b) New or amended safety rules shall be effective one calendar month from the end of the Plenary meeting of that year or for the next CIAM approved competition, in the category affected, whichever is the sooner.
- c) Any amended or new safety rule(s) shall appear in the Organiser Bulletins of the appropriate Championship(s) being held that year.
- d) All safety rules shall be the responsibility of the Technical Secretary who shall liaise with the appropriate Sub-Committee Chairman regarding specific safety rule(s).
- e) See A.3.7.1.d

A.4. SUB-COMMITTEES

- A.4.1. The CIAM may set up Sub-committees, which are consulted by it for advice on sporting and technical matters in the special category concerned.

- A.4.2. The CIAM elects by secret ballot the Chairman of each Technical Sub-committee and the Education Sub-committee for a period of two years, with a compulsory confirmation after one year. The election shall occur at the Plenary Meeting during the year in which a Sub-committee may have a regularly scheduled meeting for decision purposes and in which a World Championship for the subject category is held.

cont/...

For F1, the election year is the year in which the F1ABC senior world championships take place and for F3 Soaring it is the year in which the F3B world championship takes place.

The Chairman may be re-elected for an unlimited number of terms. He may not serve on more than one Sub-committee simultaneously

World Championships are held as follows:

World Championships in Odd years	World Championships in Even Years
F1A-B-C Seniors	F1A-B-P Juniors
F1E	F1D (Seniors & Juniors)
F3A	F2A-B-C-D
F3B	F3F
F3C	F3J
F3D	F4C
F3K	F5B
	F5D
	Space Modelling (Seniors & Juniors)

- A.4.3. Each Sub-committee shall consist of a minimum of six members including the Chairman, all of different nationality, regardless of the number of members. The Sub-committee Chairmen shall on their own initiative invite the members, but they must be approved by their National Airports Controls. The NACs may suggest but not appoint alternative members. The Sub-committee Chairman must publish on the official FAI website, a list of the members of his Committee by 1 May of every year.
- A.4.4. The Sub-committee members serve as individual expert consultants and are not obliged to represent the views of their National Airports Controls.
- A.4.5. The Subcommittee Chairman will circulate the Plenary Meeting's official agenda to the Subcommittee members and ask for a vote, this vote to be presented to the Plenary meeting together with the result from the Technical meeting at the Plenary.

A.5 FORMS OF SUB-COMMITTEE WORK

- A.5.1 The Sub-committee Chairmen are free to organise the work of their Sub-committees, meetings, correspondence etc., as they consider most efficient. The Chairmen must send a list of the members of their respective Sub-committees as soon as they have been established to the CIAM President and the FAI office. The same procedure applies for any changes in the membership of the Sub-committees.
- A.5.2. The Sub-committees may in no case publish recommendations, guides or rules, which have not been previously approved by the CIAM or the Bureau.

A.6. PROPOSAL SUBMITTED TO THE CIAM

A.6.1 Each proposal must conform to the following requirements:

- State the volume in the Sporting Code, or its relevant approved amendments, to which the proposal refers.
- Quote the relevant paragraph and/or heading from the Sporting Code.
- Detail exactly what the alteration or addition to the wording is to be. Deleted text should be shown as strike-through, new text as bold underlined format.
- Give the reason(s) behind the proposed alteration in a short separate paragraph.
- All technical amendments must be accompanied by supporting data.
- Submit each proposal on a separate document regardless of category. An example of a proposal appears at Annex A.2.b

cont/...

- g) All rule proposals, guides and whatever items accepted for the Agenda must be made available electronically in rich text format (RTF) or Word 97-2003 to facilitate compilation of the Agenda.
- h) Amendments to rule changes not yet implemented will not be accepted.

Note: (i) See also A.13

(ii) A Word document containing the above layout and a help file on document naming is downloadable from the FAI Website to facilitate the generation of proposals in the accepted format. An example of that layout appears in Annex A.2b.

(iii) Proposals must be submitted in either Rich Text Format (RTF) or Word 97 – 2003 format only.

A.6.2. Proposals may be submitted to the CIAM by:

- a) All National Airsport Controls and/or NAC approved CIAM delegates.
- b) The Bureau of the CIAM;
- c) The Chairmen of the Sub-committees subsequent to the agreement of the majority of the members of the Sub-committee concerned.

A.7. TIMETABLE FOR PROPOSALS TO THE CIAM PLENARY MEETING AND AGENDA FOR THIS MEETING

- A.7.1. All proposals from the Sub-committees and the NACs for the Plenary Meeting must be received electronically, in the format described in A.6.1 g) by the FAI Office between 1st August and 15th November of the year immediately preceding the Plenary Meeting at which the proposals may be considered within the appropriate two-year rule cycle.

The office will email the proposals to the relevant Sub-committee Chairmen, who must present their findings in print at the December Bureau Meeting. Proposals are to be approved at the Bureau meeting after which the Secretary sets up a draft of the Plenary Meeting Agenda to be approved by the President. The finalised Agenda will be sent to the FAI office who will arrange to send it out to the NACs according to A.1.3.

Any proposals received out of sequence with the appropriate two-year cycle (see A.13) will need to be re-submitted by the proposer in the correct year.

Note: Neither the CIAM nor the FAI Secretariat has the resources to retain such proposals on file until the next Plenary meeting.

A.8. LANGUAGES

- A.8.1. The working language of the CIAM is English.

A.9. CONTEST CALENDAR

- A.9.1. Requests for contests to be put on the FAI International Contest Calendar must be received by the FAI Office no later than the 15 November, with the name, address, telephone, fax etc. of a contact person for additional information. The form to be used is shown in Annex 2 of this section.

All applications for contests must be accompanied by a fee to CIAM. The amount of this fee is determined annually by CIAM as defined in paragraph A.14.1. Payment may be made by credit card or bank transfer but in any case, the remitter pays all card or bank charges. If the fee is not received by 15 November, the contest will be deleted from the calendar.

Open International contests may be requested for approval in between CIAM meetings, if submitted at least three months in advance to the FAI Office with copies to the CIAM President and Secretary. Open International applications received by the FAI office later than 15 November will not be eligible for inclusion in a World Cup for the following year.

Sanction fees and documents for World and Continental Championships and World cup competitions must be received by the FAI by 15 November of the year preceding the Championships or World Cup competition.

- A.9.2. The Bureau has the right at any time to remove any contest from the CIAM Calendar if, in the

opinion of the Bureau, the organisation would not appear to be up to the expected standard. The President will ensure that all National Airsports Controls are informed.

A.10 SANCTION FEES

A sanction fee is required for listing any type of international contest in the FAI Contest Calendar.

The sanctions fees are as follows:

Limited international contests :

World Championship	= 500 Euro
Continental Championship	= 300 Euro
Other Limited International Contest	= 70 Euro

Other contests :

Open International Contest (including World Cup)	= 70 Euro.
Open National contest or a contest in an International Series	= 40 Euro.

The sanction fees shall be reviewed each year by the Bureau and any proposed fee changes must be approved by the Plenary Meeting.

A.11. JUDGES LISTS

Nominations for persons to be put on the List of International Judges must be received by the FAI Office no later than November 15. The nominations are valid for two years starting the following January and can be updated annually. If no list is returned by the deadline in any year, then the old one stands for one more year. Judges shall be chosen from the list. Any judges appointed for a Championship must be on the list when selected. The nomination must contain the information requested by the FAI Secretariat on the electronic form is sends to NACs.

For subjective judging, a proportion of the judges chosen to judge at a championship must not have judged at the previous equivalent championship. This proportion to be as defined in the class rules.

A.12. TECHNICAL EXPERTS LIST

Nominations for persons to be put on the list of technical experts from which the elected Subcommittee Chairmen can choose their members, must be received by the FAI Office no later than November 15. The list is valid for two years starting the following January and updated annually.

The nominations are valid for two years starting the following January and can be updated annually. If no list is presented by the deadline in any year, then the old list stands for one more year. Subcommittee members should be chosen from the list. The nomination must contain the information requested by the FAI Secretariat on the electronic forms it sends to NACs.

The Subcommittees' terms of office will be between Plenary Meetings.

A.13. EFFECTIVE DATE OF RULE CHANGES

For all classes, including official classes without championship status, a period of two years of no changes to model aircraft/space model specifications, manoeuvre schedules and competition rules will be strictly enforced.

The two-year cycle shall be as follows:

Championship classes: in step with the World Championship cycle.

Official classes: in step with the second year of the two-year anniversary cycle of the date of the Plenary Meeting at which the class was approved as official.

Rules can be amended in the years as follows:

Championship Classes in the year of a World Championship.

Official classes in the second year of the two-year cycle.

Any change will become effective the following January.

Provisional classes are not subject to this two-year rule cycle.

cont/...

The only exceptions allowed to the procedure above are genuine and urgent safety matters, indispensable rule clarifications and noise rulings.

Under normal circumstances, in step with the rule change procedure, a Technical Meeting may be held at the Plenary meeting during each year there is a World Championship in that class. In case of emergency, safety proposals or issues considered urgent by the Sub-committee Chairman, the Chairman is entitled to schedule an interim meeting.

All proposals are first to be carefully scrutinised by the Chairmen of the relevant Sub-committees who will check them for validity before presenting them to the Bureau. It will be the Chairman's duty to point out any ambiguities or lack of conformity with CIAM requirements in the proposal, as well as any effects it may have on other regulations. Apart from the exceptions stated above, proposals will only be accepted on Plenary agendas in years for which Technical Meetings are entitled to be held. This shall not apply to provisional classes.

The following schedule will be used for the Sporting Code preparation:

- a) Within two weeks following the March Plenary Meeting, each Sub-committee Chairman and the Technical Secretary shall insert the proposals approved for implementation the following year. This text shall be held on the private Bureau worksite as a working draft copy.
- b) Upon publication of the final Plenary Minutes, the draft shall be reviewed for accuracy and necessary changes made at that time. The reviewed draft shall be completed by August 1st and released to FAI headquarters for proper formatting and final preparation.
- c) By October 1st, the finalised Sporting Code shall be released to the official CIAM delegates' list for comments. Any comments or correction deemed necessary will be forwarded to the Technical Secretary who will bring them before the November/December Bureau meeting for consideration and possible action.
- d) Following the November/December Bureau meeting, the amended Sporting Code shall be released to the general FAI/CIAM website no later than January 1st.

A.14. AEROMODELLING FUND

A.14.1. An Aeromodelling Fund shall be maintained to hold monies paid as sanction fees for listing events in the FAI Sporting Calendar. See A.10 for the sanction fees.

A.14.2. The fund shall be used for:

- a) paying of unrecouped costs of publishing the CIAM Flyer;
- b) paying the cost of FAI Medals and Diplomas for Model Aircraft and Space-modelling World Cup events;
- c) paying the cost of refurbishment of World Championship Trophies when required;
- d) re-imbusement of the transport and accommodation costs incurred by the CIAM President or his alternate in attending the FAI General Conference, the CIAM Bureau and Plenary Meetings;
- e) paying the costs, to the limit of available funds in any year, not properly a charge on a NAC, of attendance at Bureau Meetings;
- f) the single payment for the CIAM Aeromodelling Scholarship as and when it is awarded (see A.18).

A.15. CHANGE FROM PROVISIONAL TO OFFICIAL RULES

A.15.1. Before being considered for adoption by the CIAM as official FAI rules, provisional rules must first have been used in at least five international contests, involving a total of at least five FAI member countries (but not necessarily five countries per contest).

A.15.2. Where there is great demand for a class, the Plenary Meeting may decide to waive the conditions contained in paragraph A.15.1 and adopt the provisional rules as official rules, effective from the following January.

A.16. ELIGIBILITY FOR WORLD AND CONTINENTAL CHAMPIONSHIPS

A.16.1. Before they can be considered by the CIAM for use in World and/or Continental Championships, there must be a minimum period of two years from the time the rules were made official during which at least two

international contests were held, each with a minimum of five FAI member nations participating. Also, reports from the Chairman of the Jury in each contest must be sent to the appropriate Sub-committee Chairman for the latter's recommendation to the CIAM.

cont/...

A.16.2 In cases where the conditions in A.15.1 have been waived, the rules may be considered eligible for use in World and/or Continental Championships from, and including, the year in which they became effective.

A.17 NATIONAL RULES

A.17.1 In order to attract more participants in model aircraft competitions, each NAC may establish in addition to FAI rules, further model aircraft classes. The general section and model aircraft specifications should be the same as official FAI model aircraft classes.

A.18 AEROMODELLING SCHOLARSHIP

The Aeromodelling Scholarship may be awarded to one appropriately qualified person up to 21 years of age in the year of nomination.

Only one person from a country may be nominated annually by that candidate's NAC.

Only one Scholarship may be awarded in any one year.

Procedure

A NAC sends to the FAI office the Nomination Form duly completed, stamped and signed plus the required documentation to be received by 15 November. (see ABR Annex A.2m for the nomination form and details.)

All forms and attached documentation, including personal statements, will be forwarded to the CIAM Scholarship Selection Group of seven world-wide Education Experts, who shall independently consider the nominations and place the candidates in descending order of merit. Any member of the Selection Group who is related to, or close friends with, any of the nominees must recuse himself from the selection procedure of that year.

The Bureau shall scrutinise the recommendations and nominate one candidate to be presented to the Plenary Meeting for approval. The Plenary Meeting awards the Scholarship

Payment

The FAI will transfer the Scholarship award of 2,000 Euros to the appropriate NAC. This NAC office shall pay the tuition fees of schools, colleges or universities or the financial funding of educational books or other educational facilities directly to the educational establishment.

Monies shall not be sent to the sponsored students, the parents or guardians.

The NAC shall forward all receipts to the FAI office for forwarding to the CIAM Treasurer for monitoring purposes.

The delegate of the NAC administering the Scholarship award shall present a report to Plenary at the following Plenary meeting (to be received by the FAI office by the previous 15 November).

Note i: The CIAM Scholarship cycle:

<i>March 2009</i>	<i>- Plenary approval</i>
<i>January 2010</i>	<i>- Rule effective</i>
<i>March 2010</i>	<i>- Education Scholarship Group members "appointed"</i>
<i>November 2010</i>	<i>- 1st time candidate submissions deadline</i>
<i>March 2011</i>	<i>- 1st time candidate approved</i>
<i>November 2011</i>	<i>- 1st CIAM Scholar's report by Delegate deadline</i> <i>- 2nd time candidate submissions deadline</i>
<i>March 2012</i>	<i>- 1st CIAM Scholar's report presented to Plenary</i> <i>- 2nd time candidate approved</i>
<i>November 2012</i>	<i>- 2nd CIAM Scholar's report by Delegate deadline</i> <i>- 3rd time candidate submissions deadline</i>

Note ii: The nomination form may be downloaded from the CIAM website.

ANNEX A.1a

GUIDE FOR SUBMITTING A BID TO PLENARY TO HOST A WORLD OR CONTINENTAL CHAMPIONSHIP

For successful bids, the actual dates must be presented no later than the Plenary Meeting in the year preceding the Championships.

The bid must include:

Year

Type of championship where the championship name conforms to CIAM championship naming policy (see Annex A.1c for the list of appropriate championship names).

Category/categories of model flying

Submitting country

Submitting NAC

Organiser of championship including contact name, telephone & fax numbers & email address

Proposed month of championship

Class(es)

Venue

Flying site details

Transportation:

To country

To flying site

Planned accommodation details

Planned catering details

Local weather information

Visa requirements

Special insurance requirements

Planned initiatives for media involvement and management of spectators

ANNEX A.1b

GUIDE FOR SUBMITTING WORLD AND CONTINENTAL CHAMPIONSHIP ORGANISER BULLETIN 0s TO CIAM BUREAU FOR APPROVAL

Organiser Bulletin 0s are draft Bulletins and must be submitted by 15th November of the year prior to the Championship to the FAI office and the CIAM Secretary for consideration at the November/December Bureau Meeting.

The organising NAC shall attend Bureau on the appropriate day, according to the published Bureau Agenda, to give further information and to answer any queries that may have arisen from the submission of Bulletin 0.

Bulletin 0s must comprise, at a minimum, the following information, in the order listed as follows:

Front Page

Year & championship title, country, "from" & "to" dates (arrival & departure), FAI, NAC & sponsor logos & Bulletin Number (0).

Note: the title of the championship must be in line with CIAM championship naming policy and a list of appropriate championship names appears in Annex A.1c.

Class(es)

List the class(es) to be flown by F designation and description.

Anti-Doping

If a competitor has to take, for a medical condition, any of the substances listed on the WADA Prohibited List then he must have a Therapeutic Use Exemption from the FAI.

FAI Jury

List the proposed FAI Jury President and members, including appropriate reserve Jury members for approval by Bureau. Refer to the rules for the composition of FAI Juries. (Refer to ABR B.4.1 – B.4.4).

Judges & Contest Director(s)

List the proposed Judges and reserve Judges for approval by Bureau, (refer to ABR B.4.2 and the appropriate Sporting Code volume for the category) and the Contest Director(s) for information.

Entry Fees:

List the obligatory entry fees to be paid by competitors, team managers, helpers and supporters and an optional fee that covers accommodation, banquet and food. All costs must be stated in Euro. Outline any other optional fees for which it may be necessary to charge such as official transportation, or an optional tour.

Accommodation and Catering

List the type of accommodation and whether the rooms are single, twin or multiple bedded with the cost per person of each variation. Offer a camping option if possible.

State whether there will be official meals and, if so, list the cost. If there are no official meals then include a guide on the price of local restaurant meals.

Dates

Show the full competition schedule in sequential order by day and date starting with the arrival day and include the registration, processing, official practice, free practice, reserve date, opening & closing ceremonies, prizegiving & banquet and departure dates.

cont/...

Reserve Day

One day must be set aside as a free day near the end of the competition to allow for completion of flying if the schedule is delayed by weather or other factors. It is of primary importance to complete the flying schedule.

If other activities are scheduled on that day, then these are secondary to the completion of the Championship.

Tour

It is not necessary to offer a tour. However, if a tour is offered, then it must be made clear that **this is optional** and its fee must be separate from the main entry.

Teams:

State the total number of competitors permitted from each country in each class plus the Team Manager, an Assistant Team Manager if permitted by the rules, (refer to ABR B.3.6) and any additional personnel such as time-keepers or helpers permitted by the rules.

Awards

State that FAI medals and FAI diplomas for 1-2-3 individuals and teams (including Team Managers) will be awarded for World and Continental Championships.

State if additional organiser prizes will be awarded.

Location

Describe the area and enclose a diagram or map showing the main routes to the flying site and the accommodation and from the accommodation to the flying sites.

Transportation

Indicate if any transportation will be provided by the organiser and what the cost of that will be to each person.

Organiser Contact Details

List the name, address, telephone, fax and e-mail address of the person to whom all correspondence concerning the Championship should be addressed.

List any other relevant contest personnel.

Budget

Present a budget for the total cost of the event to enable CIAM Bureau to confirm that the entry fees and accommodation and meal charges have been set at a reasonable level in accordance with ABR B.7.2 & B.7.4.

Spectators & Media

Detail the arrangements aimed at attracting and managing spectators and media.

Notes:

- 1. The budget must be presented on a separate sheet as information for only the Bureau members.*
- 2. Further details that will be included in Bulletin 1 may be included in Bulletin 0 in the appropriate place.*
- 3. Bulletin 0 is a draft Bulletin for the benefit of CIAM Bureau and should not be issued, published or publicised outside the CIAM Bureau.**
- 4. After Bureau approval of Bulletin 0, Bulletin 1 (as a revision of Bulletin 0 and including any changes directed by Bureau) must be issued to NACs & the FAI office. **The procedure that organisers must follow is detailed at B.7.1***

ANNEX A.1c

CIAM POLICY FOR NAMING OF CHAMPIONSHIPS

Effective 1st March 2008

FAI WORLD CHAMPIONSHIPS FOR FREE FLIGHT MODEL AIRCRAFT
FAI JUNIOR WORLD CHAMPIONSHIPS FOR FREE FLIGHT MODEL AIRCRAFT
FAI WORLD CHAMPIONSHIPS FOR CONTROL LINE MODEL AIRCRAFT
FAI WORLD CHAMPIONSHIP FOR AEROBATIC MODEL AIRCRAFT
FAI WORLD CHAMPIONSHIP FOR SOARING MODEL AIRCRAFT
FAI WORLD CHAMPIONSHIP FOR MODEL HELICOPTERS
FAI WORLD CHAMPIONSHIP FOR PYLON RACING MODEL AIRCRAFT
FAI WORLD CHAMPIONSHIPS FOR SCALE MODEL AIRCRAFT
FAI WORLD CHAMPIONSHIPS FOR ELECTRIC MODEL AIRCRAFT
FAI WORLD CHAMPIONSHIPS FOR SPACE MODELS

- Where:
- a) The plural "Championships" is used only when the competition covers multiple classes.
 - b) The word "World" should be substituted with "European", "Asian", "Oceanic" etc as appropriate.
 - c) The word "FAI" may be substituted with the FAI logo in a position immediately adjacent to the Championship title.

Note: Ref item 10 of the Minutes of the Bureau Meeting of 30th November/1st December 2007

ANNEX A.2a



FEDERATION AERONAUTIQUE INTERNATIONALE Registration of Competitions in the FAI Aeromodelling Sporting Calendar

This form must be received by the Head Office **by November 15** in order that the subject event may be included **in the first issue** of the following year's FAI-CIAM Sporting Calendar.

National Air Sport Control (NAC):

Address:

Country:

Date:

Official stamp of NAC

The NAC of (country) wishes to have the following competition listed in the FAI Aeromodelling Sporting Calendar for the year (Use only **ONE** form per competition)

Attention is called to Article B.2 of Section 4 of the Sporting Code defining the type of international events.

Please send this form duly completed to:

FAI – Avenue Mon-Repos 24 – 1005 Lausanne – Switzerland

Fax no: +41 21 345 10 77

Provide the following information:

1. Type of Event
- World Championship
 - Continental Championship
 - Open International – World Cup
 - Open International – Non World Cup
 - Open International – WAG Selection Contest (even years only)
 - Limited International Contest
 - Open National & International Series

2. Title of Event:

3. Class of Model(s) (e.g. F1A, F3B, F4C, etc):

4. Dates of Event:

5. Alternate Date:
(in the event of a clash of dates)

6. Location (City):

Location (Country):

7. Entry Fees: €

8. Organiser:

9. Contact Person:

10. Address:

Phone:

Fax:

Email:

Web site:

This request must be accompanied by a Sanction Fee. **World Cup sanction fees must be paid by 15 November.**

With effect from the year 2011, the fees for single line listing of events in the FAI Sporting Calendar are:

World Championship	€ 500
Continental Championship	€ 300
Open International Contest	€ 70
Limited International Contest	€ 70
Open National Contest	€ 40
International Series Contest	€ 40

Make payments by bank transfer or credit card.

Bank transfer payments must be made to:

FAI Account no: 0425-457968-32

Swift Code: CRES CHZZ 10A

IBAN Code: CH31 0483 5045 7968 3200 0

Purpose of transfer: *name of the event*

Credit Suisse Private Banking

Rue du Lion d'Or 5-7, Case postale 2468

1002 Lausanne – Switzerland

Credit card payments must be made using the form downloadable from the CIAM website.

All bank/card charges must be paid by the submitting organisation.

Signature of NAC Authority

ANNEX A.2b

EXPLANATION OF THE COMPLETION OF A PROPOSAL FOR SUBMISSION TO CIAM (Conforming to the rules in A.6.1. of Volume ABR effective Plenary 2009)

Reference Plenary 2010 - submit the proposal between 1st August and 15th November in the year immediately preceding the Plenary Meeting but in line with the 2-year cycle.

Date: xx

Proposal submitted by: Country or Subcommittee Chairman on behalf of the Subcommittee

-For proposals from Subcommittees: Voting Numbers Required:
Overall Votes Cast: For: Against:

Sporting Code Volume: F Category Section 4 or ABR Section 4A, 4B, 4C.

Heading of section: *Very occasionally the Sporting Code does not contain a heading but if it does, it must be included.*

Class: Fxx

Number & heading of the paragraph: x.x.x. & heading - as shown in the appropriate section of the Sporting Code.

Page number if appropriate: xx

This proposal is a:

Rule Change	<input type="checkbox"/>	Safety	<input type="checkbox"/>	Noise	<input type="checkbox"/>	Other	<input type="checkbox"/>
Clarification	<input type="checkbox"/>						

mark the boxes with **X** as appropriate

Type the instruction in the space below:

For example "Add a new sentence at the end of x.x.x."

Type the text changes in the space below:

*Show deletions by strikethrough (this is an example of strikethrough); **additions by bold underlined.***

Type out the reasons in the space below:

Explain the reasoning for the proposal.

Type out supporting data for proposed technical amendments in the space below:

This is not always necessary or available but if it is then type it in here or on a separate sheet if necessary.

Notes:

- (i) Each file must contain only one proposal. Multiple proposals in one file are no longer permissible.
- (ii) It is no longer necessary to send a hard copy to the FAI office.
- (iii) Always use the correct file naming as shown in the help file that is downloaded along with (v) below.
- (iv) Proposals must be submitted in Rich Text Format (RTF) or Word versions 97-2003.
- (v) Correct electronic files on which to submit proposals may be downloaded from the CIAM Documents page on the FAI website. Please note that proposals received on old forms will not be accepted and will be returned to the NAC(s).

ANNEX A.2c (Page 1 of 2)

Submissions of nominations for Aeromodelling International FAI Judges are now initiated by the FAI Secretariat and forms are sent electronically to each NAC, therefore the redundant cover form in this Annex has been deleted.

ANNEX A.2c (Page 2 of 2)

Submissions of nominations for Aeromodelling International FAI Judges are now initiated by the FAI Secretariat and forms are sent electronically to each NAC, therefore the redundant form in this Annex has been deleted.

ANNEX A.2d (Page 1 of 2)

Submissions of nominations for Aeromodelling Technical Sub-Committees are now initiated by the FAI Secretariat and forms are sent electronically to each NAC, therefore the redundant cover form in this Annex has been deleted.

ANNEX A.2d (Page 2 of 2)

Submissions of nominations for Aeromodelling Technical Sub-Committees are now initiated by the FAI Secretariat and forms are sent electronically to each NAC, therefore the redundant form in this Annex has been deleted.

ANNEX A.2e

The form for the nomination of CIAM office holders is an internal CIAM/FAI form and, therefore, has been deleted from this Annex.

**ANNEX A.2f
FEDERATION AERONAUTIQUE INTERNATIONALE**

NOMINATION FORM
THE ANTONOV DIPLOMA
(for technical innovation(s))

From NAC : _____

Date : _____

Address : _____

Country : _____

(only one person from a country may be nominated annually by that candidate's National Airsport Control)

Name of Nominee : _____

Address : _____

DESCRIPTION OF TECHNICAL INNOVATION(S) - Please Print

.....

.....

.....

.....

.....

.....

.....

.....

.....

.....

.....

NAC Signature _____

President or Secretary General of nominating FAI National Airsport Control

(must be submitted to the FAI Office by November 15)

ANNEX A.2g
FEDERATION AERONAUTIQUE INTERNATIONALE
NOMINATION FORM
THE ANDREI TUPOLEV MEDAL

(for World and National Championship victories in the same class in the same year)

From NAC : _____ Date : _____
Address : _____ Country : _____

(only one person from a country may be nominated annually by that candidate's National Airport Control)

Name of Nominee : _____
Address : _____

REQUIREMENTS - Please Print

World Championship during which the World Champion title was obtained :

Championship name:
Championship dates : Championship place:
Class of Model in which the modeller competed :

National Championship during which the National Champion title was obtained :

Championship name:
Championship dates : Championship place:
Class of Model in which the modeller competed :

NAC Signature _____

President or Secretary General of nominating FAI National Airport Control

(must be submitted to the FAI Office by November 15)

ANNEX A.2h
FEDERATION AERONAUTIQUE INTERNATIONALE
NOMINATION FORM
THE ANDREI TUPOLEV DIPLOMA

(for outstanding world record performance)



From NAC : _____

Date : _____

Address : _____

Country : _____

(only one person from a country may be nominated annually by that candidate's National Airsport Control)

Name of Nominee : _____

Address : _____

DESCRIPTION OF OUTSTANDING RECORD PERFORMANCE IN AEROMODELLING - Please Print

.....

.....

.....

.....

.....

.....

.....

.....

.....

.....

.....

NAC Signature . _____

President or Secretary General of nominating FAI National Airsport Control

(must be submitted to the FAI Office by November 15)

ANNEX A.2i
FEDERATION AERONAUTIQUE INTERNATIONALE

NOMINATION FORM

ALPHONSE PENAUD DIPLOMA

(for outstanding sporting achievements)



From NAC : _____ Date : _____

Address : _____ Country : _____

(only one person from a country may be nominated annually by that candidate's National Airsport Control)

Name of Nominee : _____

Address : _____

Requirements - one who has had either :

1. at least three times consecutively the title of National Champion :

dates : _____

2. at least the title of World Champion :

date : _____ WC :

3. at least three world records :

dates : _____

category : _____

4. other outstanding sporting achievements :

description : (please print)

.....
.....
.....
.....
.....
.....

NAC Signature _____

President or Secretary General of nominating FAI National Airsport Control

(must be submitted to the FAI Office by November 15)

ANNEX A.2j
FEDERATION AERONAUTIQUE INTERNATIONALE

NOMINATION FORM
FAI AEROMODELLING GOLD MEDAL
(for outstanding merit in organisational activities)

From NAC : _____ Date : _____

Address : _____ Country : _____

(only one person from a country may be nominated annually by that candidate's National Airsport Control)

Name of Nominee : _____

Address : _____

Requirements - one who has been either :

1. at least twice Competition Director or similar function at World or Continental Championships :

dates : _____

locations : _____

2. at least 3 times FAI Jury member at World or Continental Championships :

dates : _____

locations : _____

3. at least 5 times judge or similar function at World or Continental Championships :

dates : _____ locations : _____

4. at least 3 years NAC delegate to FAI Aeromodelling Commission (CIAM) or another function within CIAM :

dates : _____

5. shown outstanding merits in developing aeromodelling by organisational activities :

description : (please print)

.....
.....
.....

NAC Signature _____
President or Secretary General of nominating FAI National Airsport Control
(must be submitted to the FAI Office by November 15)

ANNEX A.2k
FEDERATION AERONAUTIQUE INTERNATIONALE
NOMINATION FORM
THE FRANK EHLING DIPLOMA

(for outstanding accomplishment, by an organisation or individual, in connection with the promotion of aviation through the use of flying models)

From NAC : _____

Date : _____

Address : _____

Country : _____

(only one person from a country may be nominated annually by that candidate's National Airsport Control)

Name of Nominee : _____

Address : _____

FULL INFORMATION ABOUT THE CANDIDATE'S ACTIVITIES UP TO 31st DECEMBER OF THE PRECEDING YEAR - Please Print

.....
.....
.....
.....
.....
.....
.....
.....
.....
.....
.....
.....

NAC Signature _____

President or Secretary General of nominating FAI National Airsport Control

(must be submitted to the FAI Office by November 15)

Note: "I" is not used in Annex numbering

ANNEX A.2m
FEDERATION AERONAUTIQUE INTERNATIONALE
NOMINATION FORM
CIAM AEROMODELLING SCHOLARSHIP

(for applicants up to the age of 21 in the year of nomination)

From NAC : _____ Date : _____

Address : _____ Country : _____

(only one person from a country may be nominated annually by that candidate's National Airsport Control)

Name of Nominee : _____ Date of birth: _____

Address : _____

Scholastic Accomplishments and Educational Plans (please list & continue on a separate sheet if necessary):

Aeromodelling Achievements up to the age of 21 (for example World or Continental Championships, National Championships, World Cups, Records, Technical Innovations. In the case of competitions, include the name, date, and location of each competition, the class and the position achieved) (please list & continue on a separate sheet if necessary)

Personal Statement: What role did Aeromodelling play in your life and what are your aspirations for the future? (One page to be written in the Nominee's own hand and attached to this form. If written in a language other than English, then please attach a typed translation as well as the hand-written original.)

NAC Signature. _____

President or Secretary General of nominating FAI National Airsport Control

(must be submitted to the FAI Office by November 15)

SECTION 4B

GENERAL RULES FOR INTERNATIONAL CONTESTS

B.1. GENERAL DEFINITION OF INTERNATIONAL CONTESTS

Any model aircraft and space modelling event in which the competitors are persons or teams from at least two different nations. Organised by the NAC or with its permission or participation under the rules of the Sporting Code Sections 4b and 4, these contests must be entered in the FAI Contest Calendar (the form is at Annex A.2a) and are open only to persons holding a valid Sporting Licence of the FAI.

B.2. TYPES OF INTERNATIONAL CONTESTS

B.2.1. Open International Contests

Contests in which all competitors who possess an FAI Sporting Licence may enter. These contests are for individual classification only.

B.2.2. Limited International Contests

Contests in which all competitors are nominated by their NAC. These contests are for individual and possibly team classification.

B.2.3. Continental Championships

These are limited international contests in which the competitors are nominated by their NACs and are persons or teams from at least four different nations from one continent. These contests are for individual and possibly team classification and will be organised only in the years when there is no World Championship in the particular class.

The number of classes in one Continental Championship is limited to five (5) for Seniors and five (5) for Juniors except for the case of Space Models, where the number of classes shall be limited to eight (8) for Seniors and eight (8) for Juniors.

B.2.4. World Championships

These are limited international contests in which the competitors must be nominated by their NAC. These contests are for individual and national team classification. The Sporting Code General Section 3.5.1 applies.

The World Championships shall be planned and scheduled by the CIAM.

Each World Championships is normally held every other year.

The number of classes in one World Championship is limited to five (5) for Seniors and five (5) for Juniors except for the case of Space Models, where the number of classes shall be limited to eight (8) for Seniors and eight (8) for Juniors.

B.2.5. World Air Games

These are limited international contests in which the competitors are selected by the respective Air Sport Commissions on the basis of International Ranking Lists and/or previous championship results. These contests are for individual classification only.

B.2.6. World Cup

This is a classification of the results of special open international contests during a year. A World Cup may be organised by the relevant CIAM Sub-committee for any of its classes.

If a CIAM Sub-committee chooses to run a World Cup, it must:

- a) define rules and points allocation; these must be published in the Sporting Code;
- b) nominate in advance the open international contests which are to be included from the FAI Sporting Calendar;

- c) Check the draft FAI Sporting Calendar for errors or omissions and report to the December Bureau meeting.
- d) Send a reminder communication to World Cup contest organisers at the beginning of each year. This communication is to:
 - request confirmation of the contest details in the FAI Sporting Calendar;
 - remind of the requirement to observe the Sporting Code (B.5.1);
 - remind of the requirement to check FAI licences of entrants;
 - remind of the requirements for submission of results in (B.5.5.);
 - give a valid email address to which the results should be sent;
- e) collect results from each competition and allocate points to competitors (refer also to paragraphs B.5.5);
- f) produce and distribute current positions in the World Cup during the year;
- g) advise Bureau of any problems with any World Cup contests;
- h) in each category, award a medal and diploma from the FAI to the winner and a diploma from the FAI to the second and third places;
- i) the Sub-committee may appoint a World Cup Co-ordinator to administer the World Cup. If it does so, then items c) to h) above are the direct responsibility of the World Cup Co-ordinator. The Sub-committee Chairman shall advise Bureau of the name of the World Cup Co-ordinator.

B.2.7. International Ranking

This is a continuous classification based on the results of all open and international events, as well as World and Continental Championships, World Cup contests and World Air Games selection events. An international ranking may be organised by the relevant CIAM Sub-committee for any of the classes recognised as World Championships or World Air Games classes.

If a CIAM Sub-committee chooses to run an international ranking, it must:

- a) Define rules and ranking algorithm, these must be published in the Sporting Code.
- b) Collect results from each competition and apply the ranking algorithm on them.
- c) Produce and distribute up-dated ranking lists during the year.

B.2.8. Open Nationals and International Series

The responsibility for the event shall be that of the NAC of the country where the event takes place. The participants must have a valid FAI license.

These contests are for individual classification only.

An Open National contest is defined in the Sporting Code General Section 3.1.4.

An International Series is a sequence of international contests for specific goal or classification for example such as Eurotour contests but excluding World Cups.

B.2.9. First Category Events

First category events for aeromodelling are World and Continental Championships. The World Air Games are also considered to be a first category event by the FAI.

All other types of aeromodelling international contests are considered to be second category events.

B.3. COMPETITORS AND TEAMS

B.3.1. Competitor

- a) Unless stated otherwise, the competitor named on the entry form must be builder of the model aircraft entered.
- b) Any competitor who has to take any of the substances on the WADA Prohibited List for a medical condition must have a Therapeutic Use Exemption (TUE) granted by the FAI. (See B.3.7.)

cont/...

- c) Any conscious effort by a competitor, or a team member or helper directly involved with a national team, to influence, intimidate, or threaten contest officials or other competitors or teams, with the intent of gaining an advantage over other competitors or teams, irrespective if this occurs directly before, during, or directly after the sporting event, shall be considered as unsporting behaviour, and may result in disqualification of the individual or the team from the championship.

B.3.2. Sporting Licences

- a) Every competitor, team manager and assistant team manager entering an international contest must possess a valid Sporting Licence of the FAI. This Sporting Licence is issued by the NAC of the competitor, team manager or assistant team manager under the conditions of the General Section of the Sporting Code and must bear the national identification mark.
- b) Organisers of any international competition must check FAI licences and must not permit entry to the competition to anyone who does not have a valid FAI licence.
- c) Competitors who hold an FAI Sporting Licence issued directly by the FAI office enter as "FAI Applicants" and in entry and results list their nationality shall be shown as "FAI".

B.3.3. Competitor's Proxy and Substitution of Team Members

Proxy flights are not permitted in any class or category of either model aircraft or space models. Substitution of team members is permitted only up to the time of registration or prior to model processing, whichever comes first.

B.3.4. Age Classification for the Contest

A competitor is considered to be a junior up to and including the calendar year in which he attains the age of 18. All other competitors are classed as Seniors.

- a) World or Continental Championships may be organised specifically for juniors. At these Junior Championships, all competitors and all helpers, team members, mechanics and assistants must all be juniors. The team managers and/or their duly registered assistants and organising officials are the only seniors allowed in the starting area. For RC Soaring the helpers, mechanics and assistants may be seniors. For a disabled junior, the start helper (5.7.1.3) must also be a junior.
- b) At F1D World and Continental Championships, when juniors and seniors fly together in the same site and at the same time, the junior competitors who are members of a national Senior team will appear in the individual senior classification, but must also be considered in the national Junior team and included in the Junior individual classification as far as the Junior national team is not complete. The names of the junior national team members must be declared before the beginning of the competition
- c) If there are three or more junior entries in an Open International, there must be a separate junior classification included in the results.
- d) Any Junior World or Continental Champion who will be too old to defend his title at the next World or Continental Championships for Juniors is entitled to fly in one World or Continental Championship for Seniors, in the appropriate class, within the three calendar years following his becoming Junior World or Continental Champion.

B.3.5. National Teams for World and Continental Championships

A national team shall consist of a maximum of three individual competitors, or three pairs of competitors, for each category and a Team Manager. For those categories that do not have separate Junior Championships, the team may consist of a maximum of four individual competitors or four pairs of competitors for each category provided that the fourth competitor is a junior, plus a team manager.

The reigning World or Continental Champion has the right (subject to the approval of his National Airports Control) to participate in the next World or Continental Championships in that category regardless of whether he qualifies for the national team or not. If he is not a member of the national team, his score will not be considered in the team results.

B.3.6. Team Manager

The team manager may assist the competitors. He is the only person allowed to deal with the Jury or the Organiser in the case of disputes, complaints or protests and must be obligatory for World and Continental Championships. Any member of the officially entered national team may be nominated as team manager.

For Free Flight, Control Line, Scale and Space Model competitions, the team manager may have an assistant, registered with the organiser, who will have the same duties as the team manager except that the assistant will not be allowed to deal with the Jury or the Organiser except to deliver protests.

B.3.7. Therapeutic Use Exemption

If it is necessary for a competitor to hold a Therapeutic Use Exemption (TUE) (see B.3.1) then the application form must be completed and sent to the FAI by the competitor.

In normal circumstances the application form must arrive at the FAI at least 21 days before the start of the competition.

The FAI processing of TUEs is free, but any other costs associated with submitting a TUE must be borne by the competitor.

The TUE is effective for between one and four years depending on the medical condition for which it is issued.

B.4. CONTEST OFFICIALS

B.4.1 FAI Jury

The Organiser of all International contests included in the FAI Contest Calendar shall nominate an FAI Jury of three members at least two of whom shall be chosen for their competence in the category being flown in the event. It is the responsibility of the Jury to see that the event is conducted in accordance with the relevant provisions of the Sporting Code Section 4b and 4c, and they are empowered to make all decisions dictated by any circumstances which may arise and to rule on disputes. Before the start of the competition, the FAI Jury must make sure that the organiser has satisfied the requirements of B.8 and, where relevant, sections B.9, B.10, B.11.

The FAI Jury must have at least one language in common.

The FAI Jury at World and Continental Championships shall remain independent of the organiser(s) to enable them to enforce the rules of the FAI and act as an independent arbiter in disputes between the organiser(s) and the competitors.

The President of the Jury at each international contest must submit a report to the FAI within one month of the contest. This report must include descriptions of any deviation from the Sporting Code and any exceptional circumstances that arose. In the situation where a new world record is set during a World or Continental Championship, it is the responsibility of the FAI Jury for that event to notify the FAI Headquarters within seven (7) days of the record accomplishment and remind the competitor and organisers of the need to assemble proper documentation within the prescribed time limit for homologation.

Bureau members, Sub-committee Chairmen, any delegate and relevant Sub-committee members are, in an emergency, automatically approved in that order for appointment as Jury members .

B.4.2 In the case of World Championships, the Jury must include at least one member of the CIAM Bureau or one who, over the last 5 years, has served on the Bureau, or the Chairman of the particular CIAM Sub-committee.

The second member must be a CIAM delegate or either someone who in the past 5 years has served on a FAI World Championships Jury, or in the past 5 years has served two consecutive years on a Sub-committee in the same category as the World Championships.

The remaining member may be delegated by the NAC of the organising country provided that if the choice is made from another country approval will first have been obtained from that Jury member's NAC. The members of a WCh or CCh Jury shall be of different nationalities. All WCh and CCh Juries must be approved by the CIAM Bureau. The members of an international Jury must have recent practical judging and/or flying experience of the relevant category.

B.4.3. In the case of Continental Championships, the Jury must include at least one CIAM delegate. The three members of a Continental Championships Jury shall be of different nationalities and have the approval of their NACs.

- B.4.4. In the case of other international events, the Jury must include at least one CIAM delegate or a person approved by his NAC. The other two members can be delegated by the NAC of the organising country. Members of the Jury must be from at least two different nations.

The Jury must be announced before the start of the event. When the contest has a subdivision into categories, one or two members of the Jury may compete in a category and must then be replaced by alternate Jury members (not competing in that category) for all matters involving that category. The alternate members must be chosen so that at all times the Jury meets nationality and language rules.

For competitions which involve a single category, one or two jury members may be nominated from the competitors. An alternate jury member must also be nominated for each competitor jury member, to serve on the jury when considering any protest involving that competitor jury member. The members must be chosen so that at all time the Jury meets the nationality and language rules.

B.4.5. Contest Officials

The organisers may appoint timekeepers and other contest officials from other countries provided those are approved by their own NAC.

- B.4.6. The NAC responsible for organising a WCh or CCh shall submit to the CIAM or CIAM Bureau, for approval, the names of the persons who shall act as judges. International judges must have had recent practical judging and/or flying experience of the category for which they are selected.

- B.4.7. The organiser of a CIAM competition must bear the expenses of CIAM Bureau designated jurors and judges for accommodation and meals in the course of the competition, and all transportation costs to and from the competition site (air fare economy class). This does not apply to any Jury members who compete in the competition under the terms of B.4.4.

B.5. ORGANISATION OF INTERNATIONAL CONTESTS

B.5.1. Organisation

Each International Contest in the FAI Contest Calendar must be organised in accordance with the Sporting Code General Section and Sections 4b and 4c.

NACs organising such contests should ensure that those responsible for planning the event are familiar with the CIAM documents "General Organisation of a World Championship (Annex B.3)", the relevant Safety Guides and other Organisers' and Judges' Guides and that the guidance contained therein is followed.

The rules must be displayed at the contest ground in English and in the language of the organising country.

B.5.2. Local Rules

Local rules in exceptional circumstances:

- (a) may be established at, or imposed by, the CIAM Plenary Meeting for championships in the same or the following year, or by the organisers;
- (b) may not change the model specification or competition rules unless agreed at the CIAM Plenary Meeting;
- (c) must be published in bulletins, preferably in advance of entry deadline, but no later than the latest bulletin made available to all competitors.
- (d) decided after this point, must be issued to competitors in writing prior to the start of the contest.
- (e) may be established during the contest as necessary.

- B.5.3.** For open international competitions, including World Cups, the Organiser must limit the number of entries so that the competition can be finished within the allotted time. The maximum number of entries must be stated in the event notification. The entries shall be accepted by the Organiser in order of receipt until the limit is reached and the entry is closed. Late entrants must be notified that their entry has not been accepted.

B.5.4 Entry Forms

Entry forms must include sections for:

Name - First name - Date of Birth (Juniors only) - Postal address - Nationality - FAI Licence Number - Class(es) entered.

The organiser must acknowledge receipt of the entry form and entry fee.

For Open Internationals an entry form must be supplied to any competitor requesting one from the organiser's contact details published on the FAI Contest Calendar.

For World and Continental Championships:

- (a) entry forms must be supplied by the organisers;
- (b) in the case of an online entry form system, the organiser must email a copy of the completed entry form to each team's NAC within 24 hours of the submission otherwise payment of fees may be late.

B.5.5 Results

Results for First Category events must be sent to the FAI Secretariat as follows: electronically within 24 hours of the end of the event (General Section 3.16.2.1) and the results, signed by the FAI Jury, sent without delay (General Section 3.16.2.2). Results for other events must be despatched to the FAI and NACs taking part in the event within a month. For events included in a World Cup, the results must be despatched to the relevant World Cup Co-ordinator within a month.

The results must include each entrant's FAI sporting licence number, the full name and nationality (or "FAI" in the case of entrants who have entered with sporting licence issued direct by the FAI) and for Scale events must also include the name of the prototype air-or spacecraft subject flown by the competitor.

The nationality of competitors who have entered under General Section 3.2.1 or 3.2.3.3 shall be shown as FAI. (See also B.3.2.c.)

Results submitted to the FAI or World Cup Co-ordinator must be in electronic form to allow for publication on the official FAI website.

B.5.6 Fuel

Fuel supplied by the organisers shall be mixed from top quality material. Methanol shall be at least commercial grade without additives. Castor oil, when used, shall be at least equivalent in quality to Castrol M.

Standard Fuel

- a) When a standard FAI fuel is specified, the fuel that the organisers shall supply for practice and for the competition shall be of the same constituents, mixed in a single batch.
- b) Standard fuels which are used for competition flights shall be part of the entry fee. Practice fuel supplied by the organiser to the competitors shall be charged at cost.
- c) The standard FAI fuel for practice must be requested in advance (at the time of entry).

Non-Standard Fuel

The organisers shall make available for cost, up to 20 litres of fuel per competitor for practice flying and for use in competitions. The fuel, or constituents, must be requested in advance (at the time of entry) and the organiser shall supply at least the following:

- Methanol
- Castor oil
- Nitromethane
- Synthetic oil
- Ether
- Kerosene Jet-A1

B.6. ORGANISATION SPECIFIC TO WORLD AND CONTINENTAL CHAMPIONSHIPS EVENTS

B.6.1 It is the CIAM's responsibility to decide and award World and Continental Championships and to decide which NAC shall be delegated with the responsibility for the organisation of the Championship.

The firm acceptance of a bid will normally be made by vote of the CIAM Plenary meeting two years in advance of the year of the proposed Championship.

In order to be eligible for selection, all bids must include the details required in Annex A.1a.

Under normal circumstances, bids may be submitted:

- (a) to the FAI office at any time in the year prior to the Plenary Meeting two years in advance of the Championship year;
- (b) at the Plenary Meeting two years in advance of the Championship year.

In exceptional circumstances, the decision for awarding World and Continental Championships may be taken more than two years in advance of the year of the proposed Championship, providing a request is made by November 15 and published in the Agenda of the following Plenary Meeting.

In the event that no acceptable bid is available two years in advance, the decision may be postponed to the Plenary meeting in the year before the Championship. If no bid is accepted at that meeting, the Plenary Meeting may exceptionally delegate the decision to the CIAM Bureau meeting at the end of that year. This is the latest time at which the decision can be made to proceed with a Championship for the following year.

The actual dates must be presented no later than the Plenary Meeting in the year preceding the Championship.

B.7. CONTEST INFORMATION AND ENTRY FEES FOR WORLD & CONTINENTAL CHAMPIONSHIPS

B.7.1. Information

A first memorandum of information (Bulletin 1) and entry forms must be despatched to the NACs, also to Jury members and judges, after the Bureau meeting at which Bulletin 0 was presented and approved and at least three months before the contest.

The approval mechanism for Bulletin 1 is as follows:

Any changes or amendments instructed by the Bureau should be incorporated by the Organiser into a revised bulletin. Either the original Bulletin 0 or the revised Bulletin 0 should be named "Bulletin 1" and emailed to the CIAM Secretary.

The CIAM Secretary will check that the document contains the correct data. When he is satisfied that it is correct, he will then issue Bulletin 1 to the NAC email list and the CIAM Delegates email list with the organiser in copy. He will forward a copy to the FAI Secretariat for information."

B.7.2. Entry Fees

The entry fee will consist of an obligatory fee to be paid by all competitors and team managers and an optional fee that covers accommodation and food.

The organiser may specify a closing date for the receipt of fees. Entries received after this date may be subject to a penalty fee or may be refused by the organiser.

If an obligatory fee is required for official helpers and official supporters it must not exceed 20% of the obligatory fee for competitors.

Accredited representatives of the media shall not be required to pay an entry fee.

Items contributing to the calculation of the Basic Entry Fee are (applicable depending on local circumstances):

- contest site - rent and cost of preparation;
- organisational costs of meetings/travel of organising committee; rent or purchase, if not already available, of contest equipment such as timing devices, lap counters, sighting apparatus, processing equipment, score board, walkie-talkies, frequency control equipment, score sheets, flags, flag poles, etc. Cost of instruction and briefing session of contest officials and Jury, licences and permits (PTT, local authorities); stationery, postage (information bulletins, correspondence); rent of tents. The cost of any Official opening ceremony.

cont/...

In the event that a person is serving in more than one position (team manager, competitor, helper, mechanic, etc), he will be charged only one fee: that which represents the highest fee of the positions to be served. If at the same event, there is a senior and junior classification, any junior competitor may be a member of the senior team as well. In that case this competitor is required to pay only the entry fee for the junior's class.

B.7.3 Sponsorship

It might be possible to obtain a sponsor for one or more of the above items. This will result in a lower basic fee, therefore sponsoring is highly recommended. However, sponsoring can only be taken into account if it is absolutely certain that it will be obtained, otherwise a loss can be expected. Sponsoring negotiations should start as early as is practical.

B.7.4. Additional Fees

Separate additional fees will be offered at choice for: lodging (hotel and camping); food (banquet not included) and banquet (and possible other additional events).

Maximum fee = basic fee + lodging (hotel) + food + banquet.

With the exceptions listed below, the maximum possible fee is 600 Euro for seven nights, except for events which require more than five judges or more than seven nights.

F3B: 660 F3C: 700 F3D: 720 F4: 700 F5: 660

For World Championship events that require more than five international judges, a separate additional fee may be charged to each contestant to cover the actual cost of travel, lodging and meals for those judges in excess of five. The additional fee is limited to a maximum of 165 Euro per contestant.

The cost of hotel accommodation must be kept reasonable. Keep in mind that hotel accommodation is often the only possibility for overseas participants. Using the international standard of stars accommodation to two stars (**) or equivalent is sufficient. To keep travel expenses of the team reasonable, organisers must not use the event to force teams to pay higher than the street price for accommodation. It is up to the teams whether they wish to book their own board and lodging.

Details of an awarded offer must be submitted in Bulletin 0, via the FAI office, by November 15th to the relevant Sub-committee Chairman and the CIAM Secretary for review of the fee structure prior to consideration at the following Bureau Meeting..

Bulletin 0 must contain a clear explanation of the hotel, food & banquet costs per person per day in Euros.

Bulletin 0, after approval and including any corrections required by the Bureau meeting, shall be issued as Bulletin 1 by the organiser to the appropriate NACS as specified in B.7.1 or earlier if possible.

B.7.5. The organiser must acknowledge receipt of the entry form and entry fee.

B.8. SPECIAL CONTEST ORGANISATION REQUIREMENTS

The organisers must:

B.8.1. Secure a sufficient number of qualified officials, timekeepers and FAI Jury members.

B.8.2. Provide themselves with the necessary measuring apparatus adequate to check the characteristics of model aircraft or space models in question. A list of minimum measuring apparatus is given in the Organisers' Guide for each class.

B.8.3. Give the competitors opportunity to determine the characteristics of their models on the official measuring equipment before the contest.

B.8.4. Provide at least one practice day prior to the competition, to be announced in the invitation along with a flying schedule for the competition.

The organiser will provide a schedule for the official practice giving all competitors equal practice time. The practice day must not be extended so as to delay the start of official competition. A reserve day must be scheduled after the competition to allow for the completion of official flying in the event of weather or other delays preventing completion as scheduled.

B.8.5. The organiser must also provide the name and address of a contact person, who will be able to inform foreign teams.

B.8.6. Display the results of each round throughout the contest and publish the official results afterwards. The display and publication shall not contain any additional statistics or items other than those required by the Sporting Code. Abbreviations to indicate nationality must follow the list given in Annex B.2.

- B.8.7. Provide appropriate facilities for a Doping Control Station if requested by the National Anti-Doping Organisation of the host country or by the FAI or WADA.
- B.8.8. Establish a suitable contest area allowing the full performance of the model aircraft and safe recovery.
- B.8.9. Organisers of World and Continental Championships and of Open International events on the CIAM Contest Calendar must provide the same third party insurance cover to foreign participants that their own members enjoy domestically.
- B.8.10 All timekeeping shall be made with quartz-controlled electronic stopwatches with digital readout or an electronic system of equal or greater accuracy...

B.9. FREE FLIGHT

The organiser must:

- B.9.1. Provide a starting line in Free Flight contests for classes F1A, F1B, F1C, F1G, F1H, F1J, F1K, F1P and F1Q from which launching must take place. This starting line must be approximately at right angles to the prevailing wind direction at the start of each round.

Starting positions are indicated by markers, spaced at least 10 meters apart along the starting line. In the case of F1A, the helpers shall launch the model at this pole. Each country and any reigning champion or defending junior champion (B.3.4 c), if not a member of his national team, is allotted a starting position for the first round by draw. In each successive round, all countries move a defined number of starting positions along the line in the same direction; upon reaching the end of the line, a country takes its next position at the other end of the line. The number of starting positions to be moved is established by dividing the number of starting poles by the number of official flights, the result to be rounded up to the next whole number above. Each competitor in the fly-off is allotted a starting position by draw for each fly-off round.

Spectators are not allowed within 25 m from the starting line.

During the rounds test flying is not allowed near the starting line or upwind of the starting line. The Organiser shall specify an area to be used for test flying during the rounds.

In Free Flight contests for class F1E, provide a starting line facing the wind with, on both ends, one perpendicular parallel line following the slope. The timekeepers have to remain behind the starting line whereas the competitor can launch his model in any position on the slope between the parallel lines and below the starting line.

- B.9.2. In Free Flight events, provide each starting position with two time keepers in Championships or with at least one timekeeper for other contests. For fly-offs an additional timekeeper must be provided (i.e. three for Championships, at least two for other contests). All time keepers must have binoculars. Each starting position must be equipped with at least one tripod for supporting binoculars.

In F1E Championships each country and the reigning champion, if not a member of this national team, is allotted a pair of timekeepers for the first round by draw. In successive rounds all countries change timekeepers by moving one down the list of timekeepers. In other F1E competitions timekeepers are allocated to competitors in the order in which they arrive at the starting line, the organisers may define a working time during which the timekeepers remain available to each competitor.

B.10. CONTROL LINE

The organiser must:

- B.10.1. Provide a protective wire enclosure at C/L speed and T/R contests 2.5 m high to ensure the safety of spectators. The circuit surface shall be firm, smooth and free of grit or dust. The radius of all circles shall be clearly marked with a white line at least 25mm wide. Provision of adequate areas shall be made before and during World Championships.

B.11. RADIO CONTROL

The organiser must:

- B.11.1. Provide a smooth flight area for R/C models to facilitate take-offs and landings

cont/...

- B.11.2 There is no requirement to impound spread spectrum transmitters.
A Spread Spectrum technology receiver that transmits information back to the pilot-operated transmitter, is not considered to be a “device for the transmission of information from the model aircraft to the competitor”, provided that the only information that is transmitted is for the safe operation of the model aircraft.
- B.11.3 If there are competitors using am/fm transmitters on the same frequency band then a transmitter pound is required only for those transmitters.
- B.11.4 If an am/fm transmitter pound is found to be necessary then:
- (a) Each day, on the competition site before the start of the competition, all am/fm transmitters to be used in the competition that day must be impounded and kept under the supervision of a special official.
 - (b) All transmitters must be withdrawn at the end of the day’s flying activities, and may not be left in the pound, unless by special arrangement with the organiser.
 - (c) The transmitter pound official(s) will issue the transmitter to the competitor only when he is called to make his flight (in accordance with the procedure laid down for the class concerned).
 - (d) As soon as the flight has ended, the competitor must immediately return his transmitter to the impound official.
 - (e) A fine of 50 Euro per pilot will be imposed for failure to withdraw a transmitter, for whatever reason, during the specified period.
- B.11.5 Specific rules for am/fm transmitters:
- (a) It is not permitted to use any am/fm transmitters on the competition site during the hours of competition unless:
 - (i) making an official flight or
 - (ii) the specific permission of the contest officials has been given.
 - (b) Unless the contest director allows a change in advance, using a frequency differing from that assigned by the organiser in the starting list is considered as unauthorised transmission.
 - (c) Unless otherwise stated in the rules for a particular class the competitor is allowed only one frequency for the contest.
Note: In the case of proven interference, another single frequency may be allotted by the contest director.
 - (d) Any unauthorised transmissions during the period of the contest will result in automatic disqualification of the offender from the entire contest and render him liable to further penalties.
 - (e) The transmitter frequency must be displayed on the outside of the transmitter.
 - (f) Frequency synthesised transmitters must be designed to display the current frequency and to change to another frequency without RF transmission.
- B.11.6. The organiser must provide a spectrum analyser or other adequate radio monitoring equipment for the purpose of detecting radio interference and a means of communicating this information to the pilot(s) and/or flight line director.
- B.11.7. Unless otherwise specified, the initial starting order of the various competitors must be established by means of a random draw before the contest, and, except for F3B, F3J and F3K, frequency will not follow frequency. Team members will not be included in the same race in a heat of F3D or F5D and members of one national team must not be in the heat immediately following. For F3B, F3J and F3K, competitors from the same team should not, where possible, be drawn to fly in the next group.
- B.11.8. The organiser must survey the site of any competition event scheduled to be held in order to determine possible cases of radio interference which would affect any competitors. Any such possibilities must be reported as early as practical to participating National Airsports Controls. Frequency bands or specific frequencies which have been shown to be reasonably free from interference at the site of the competition will also be reported to the National Airsports Controls.
- Organisers must make surveys of the competition site during both weekdays and weekends to determine if any patterns of radio interference exist and notify the National Airsports Controls of any further problems- many commercial or industrial operations are weekday problems only. In any case, it is the organiser’s responsibility to make certain that all competitors in a radio controlled event are notified in advance about any known radio interference problems that may exist at the flying site and at what frequency.

B.12. SPACE MODELS

The organiser must:

- B.12.1 Provide a starting line divided in two sectors for seniors and juniors (if both classifications exist in an event). Each sector shall be composed of the launch boxes 5 x 7 metres marked by plastic, marking ribbon. The whole launching area shall be protected by marking ribbons of the access of non-authorized persons.
- B.12.2 Provide for class S8E/P:
- a) a landing line with landing circles in accordance with Volume SM paragraph 11.7.5 and relevant sub-paragraphs
 - b) a spectrum analyser or other adequate radio monitoring equipment for the purpose of detecting radio interference and a means of communicating this information to the pilot(s) and/or the RSO.
 - c) a pound where all transmitters to be used that day in S8E/P shall be impounded on the morning of the competition no later than one hour before the first competition is scheduled to begin and kept under the supervision of a special official. This official will issue the transmitter to the competitor only when the starting time for each group begins.

The transmitter frequency must be displayed on the outside of the transmitter or plug-in module or frequency switch. Also, frequency synthesised transmitters must be designed to display the current frequency and to change to another frequency without RF transmission.

- B.12.3 Provide an official clock (digital with big ciphers if possible) posted next to the score board for timing of the rounds.
- B.12.4 Provide a public-address system (which may be a megaphone at the events with smaller participation) for countdown and to inform competitors.
- B.12.5. Provide tent(s) for model preparation for flights by competitors and/or model repair in case of a bad weather. A separate tent shall be provided for computer centre with a printer for result calculations and for the FAI Jury.
- B.12.6 Provide a light, dry and warm room large enough for static judging of scale models in classes S5 and S7 with necessary measuring equipment (for measurement of length, diameters, thickness and weight) and static judging forms according to Volume SM Annex 1.
- B.12.7 Provide at least two altitude measuring devices (theodolites) for altitude classes S1, S2 and S5 with proven qualified personnel and an appropriate radio communication system for data transfer from the tracking stations to the computer centre. In the case of electronic altitude measurements all electronic altimeters shall be impounded prior to the beginning of the competition and supervised by a special official qualified and equipped with the relevant devices to check and calibrate impounded equipment when necessary.
- B.12.8 Organisers of World and Continental Championships must provide a relevant protected area and calibrated engine tester(s) of a level of accuracy according to the Volume SM paragraphs 3.12 and 3.13 to recheck samples of engines submitted for competition. An engine testing time-table shall be posted prior to the beginning of the testing and also distributed to the FAI Jury, engine testing officials and participating team managers.

Only Jury members, persons authorised by the organiser, engine-testing officials and the Team Manager or Assistant Team Manager with one competitor or helper ie two persons from the team whose engines are being tested may attend engine testing. A report of by the organiser after the completed engine testing shall confirm which engines shall be used in competitions.

The organiser also may issue a certificate with measurements and thrust-time curve upon a request of the relevant participating team.

NAC certificates issued in accordance with the Volume SM paragraph 3.10 shall be accepted for Open International space modelling events on the CIAM Contest Calendar.

cont/...

- B.12.9 Organisers of World and Continental Championships must provide lockable plastic boxes with the names of the participating countries. After all the engines have been submitted for testing and samples tested, all the engine boxes shall be impounded in a separate, secure room. The boxes shall be guarded during transportation to the field by special official(s) and delivered to the time-keepers at the relevant launching box that shall control delivery of the engines to competitors.

B.13. TIMING

Note: These paragraphs apply to Free Flight and Space Models only.

- B.13.1. Each team shall have the right to provide a timekeeper for the following classes of World and Continental Championships: F1A, F1B, F1C, F1D, F1E, S3, S4, S6, S8, S9, S10; with the organiser to be responsible for providing lodging and food only. Teams must nominate only skilled timekeepers and the timekeepers must bring binoculars, watches and tripods for their own use. The organiser must use these timekeepers as a priority, before allocating duties timekeepers of the host nation or other timekeepers.

Competitors may act as timekeepers.

- B.13.2. The timekeepers must familiarise themselves with the colour and shape of the model in order to recognise it during the flight.

- B.13.3. The flight is considered ended when the model touches the surface of the earth, encounters an obstacle which definitely terminates its flight or when it definitely disappears from the timekeeper's sight. If the model disappears behind some obstacles or in clouds, the timekeepers are to wait for ten seconds; should the model not reappear, timing will cease and the ten seconds will be subtracted from the flight time.

- B.13.4. The flights must be timed by two timekeepers during the first seven rounds and, in the fly-off, each flight must be timed by at least three timekeepers – the additional timekeepers preferably to be picked among the competitors – with quartz controlled electronic stopwatches with digital readout recording to at least 1/100th of a second.

All timekeepers must be equipped with binoculars.

- B.13.5. The timekeepers must remain within a circle of 10 metres radius during the flights and time the flights independently of each other.

- B.13.6. The time recorded is the mean of the times registered by the timekeepers, but reduced to the nearest whole number of seconds below the resulting mean time unless the difference between the times registered shows evidence of an error in the timing, in which case the organiser will determine, with the FAI Jury, which time will be registered as the official time or what action should be taken.

- B.13.7. Instructions for using binoculars at F/F Contests

- a) The binoculars must have a magnification of at least 7. On each starting position at least one of the binocular will be mounted on a tripod.
- b) The timekeeper will adjust the binoculars before timing, so as to suit his eyesight. To do this the focus will first be adjusted with the centre knob, and then by separate adjustment of the adjustable eyepiece. The distance between the eyepieces will be adjusted so as to give a circular field of view.

Note: Binoculars with no central focusing device will be adjusted by altering each eyepiece in turn.

- c) After adjustment, and scale readings will be noted. This should simplify readjustment if needed.
- d) The timekeepers must not use the binoculars whilst the model is being launched. Use of the binoculars is suggested after about one minute of flight, except that in class F1A binoculars should be used whilst the model is being launched with the aim of clearly fixing the moment of its release in case the competitor has gone far away from the starting point.
- e) Use of the binoculars must not be left until too late in the flight, when there is a risk of not finding the model with the binoculars.

cont/...

B.14. DURATION OF CONTEST

- B.14.1. Outdoor contests, including fly-off starts, must take place between the hours of sunrise and sunset, except classes F1A, F1B, F1C, also Space Models Duration. In these classes a minimum of two rounds must take place when wind and thermal activity are expected to be at a minimum. The contests may start earlier than sunrise if the distance covered by the models in relation to the size of the airfield suggests an interruption of the contest during the windiest part of the day. Such an interruption can be included in the contest programme or decided by the organisers with the approval of the Jury.
- B.14.2. The contest programme including round durations, and starting and finishing times of the contest must be clearly indicated in the regulations.

B.15. INTERRUPTION OF THE CONTEST

- B.15.1. The contest should be interrupted or the start delayed by the Jury in the following circumstances and in other exceptional circumstances decided by the Jury:
- The wind is continuously stronger than 12 m/s (9 m/s for Free Flight, Control Line, Scale and Space Models) measured at two metres above the ground at the starting line (flight line), unless specified otherwise in the category rules. for at least one minute (30 seconds for Control Line) (20 seconds for Free Flight),.
 - The visibility prohibits proper observation of the models (especially in case of F/F or R/C contest) or due to atmospheric conditions it would be dangerous to continue the competition.
 - It is necessary to reposition the starting line. This may only take place between rounds, or between tasks or groups in F3B and between rounds or groups in F3J.
 - The prevailing conditions are such that they may lead to unacceptable sporting results.
 - For F3A, F5A, F3C, F4C, F3D and F5D contests when the sun is in the manoeuvring area.
 - Any incident affecting safety or requiring access for emergency services.

In the event of an interruption during a round, the Jury must decide the action to be taken to complete, repeat, or cancel the round. The remainder of the round may be completed as soon as conditions allow, with adequate notice given to all competitors and Team Managers.

- B.15.2. In the cases described, the organiser is not obliged to return the entry fee nor repeat the contest. The results will be based on the scores of the finished rounds.
- B.15.3. An interrupted contest can be extended if the requirements of article B.14.1. are met.

B.16. CLASSIFICATION AND AWARDS AT WORLD AND CONTINENTAL CHAMPIONSHIPS

B.16.1. Individual classification

- In each contest category at a World Championship an FAI medal and diploma will be awarded to the competitors in the first, second and third places.
- In each contest category at a Continental Championship, an FAI medal and FAI diploma will be awarded to the competitors in the first, second and third places.
- If there is a Challenge Trophy, this is awarded to the NAC of the winning competitor for custody until the following Championship.
- The winner earns the title of World Champion or Continental Champion in the category.
- For those categories where a junior may participate in a Continental or World Championship National Team, individual awards for junior competitors will be awarded to the first, second and third place juniors.
- Where at least four juniors from at least four different nations participate, the winner shall earn the title of Junior World or Continental Champion in the category.

cont/...

B.16.2. Team Classification

- a) The team classification is established by adding the scores of the three team members of the team together unless there is a fourth member of the team (who must always be a junior) in which case it will be the three best scoring members. For F2C the classification is established in the same way but substitute "team" for "member". In the case of a team tie, the team with the lower sum of place numbers, given in order from the top, wins. If still equal, the best individual placing decides.
- b) For World and Continental Championships gold, silver and bronze team medals, produced by the FAI to a smaller size than the standard FAI medals, will be awarded to the first, second and third place team members and team managers, except for Space Modelling where only one medal shall be awarded per team per class per age division. The cost is to be borne by the organising NAC.
- c) When teams consist of four competitors or, in the case of F2C, four pairs of competitors (ref B.3.5) then all the team members in first, second and third place will be awarded medals.
- d) In each class a diploma will be awarded by the FAI to each member including the team manager of the teams in first, second and third places.
- e) If there is a Challenge Trophy, this will be awarded to the NAC of the winning team for custody until the following Championship.

B.16.3 Team Classification – Multiple Contest Categories

- a) In a World or Continental Championships with more than one contest category a classification may be made of the overall performance of the competing nations. This is established by taking the total scores of the three members of the teams or, in a four member team ie one containing a Junior, the three best scoring members in all of the contest categories.

The highest total wins the award. In the case of a tie, the nation with the lower sum of team place numbers, given in order from the top, wins. If still equal, the total of the best individual placings in each class will decide.

- b) If there is a Challenge Trophy, this will be awarded to the NAC of the winning team for custody until the following Championship.
- c) There are no FAI medal or diploma awards assigned for this classification.

B.16.4 Award Ceremony Procedure

- a). A person from the ceremony staff will escort the medal winners to the medal staging area.
- b) The awards podium, flags of the three medal winners and the National Anthem of the Gold Medal winner will be prepared in advance.
- c) The announcer will introduce the award ceremony and then announce the category/class (as appropriate) receiving the medals as they march out in order with an escort to a position behind the awards podium.

The awards podium will be set up in the following configuration:

Silver – Left-hand side (as viewed by the spectators) – Second highest podium (2)

Gold – Centre – Highest podium (1)

Bronze – Right-hand side – The same height or slightly lower than Silver (3)

(The marching order must be in a sequence to position the medal winners behind the correct podium)

- d) The announcer will mention who (with title) will award the medals and diplomas (usually the FAI President, Air Sport Commission President or his designee.
- e) The competitor or team will be called by name and country separately and in the order – Bronze, Silver, Gold. The medal winner will step up on the podium when called by the announcer.
- f) First, the Bronze medal winning individual or team will step up to the podium and the medal and diploma will be awarded. Next, the Silver medal winning individual or team will be called to the podium and will receive the medal and diploma, followed by the Gold medal presentation using the same procedure. A moment will be allowed after the award of each medal for photographs.
- g) After all medals are awarded, the anthem of the Gold medal individual or team will be played as their country flag is raised (if no country anthem, play the FAI anthem). The flagpoles should be of different heights with the tallest in the centre for the 1st placed competitor and the two shorter ones to the left and right for the 2nd and 3rd placed competitors. All flags should be raised to the top of each pole.

cont/...

- h) The individual or team winners will pose for group photographs for a minute before stepping off the award podium and being escorted away by the ceremony escort(s).
- i) First, second and third placed competitors (including 1st, 2nd and 3rd placed national teams) must attend the award ceremonies; all competitors are expected to attend the award ceremonies.

B.17. PROCESSING OF MODEL AIRCRAFT

B.17.1. The number of model aircraft eligible for entry are as follows

Class F4C	One (1) only	
Class F2A, F2B, F3A, F3C, F5B, F3M	Two (2) only	
Class F3D, F2C, F3B, F3J, F5D, F3F, F3P	Three (3) only	
Class F1A, F1B, F1C, F1P	Four (4) only	
Class F1E, F3K	Five (5) only	
Class F1D, F2D	unlimited (two per heat in F2D)	

- B.17.2. Any model may only be used by one competitor during a competition.
- B.17.3. The competitor may provide himself with spare propellers and rubber motors, piston motors, electric motors or gas turbines.
- B.17.4. A competitor may interchange various parts as he wishes provided the resulting model conforms to the rules of the contest and that the parts have been checked before the start of the contest.
- B.17.5. Repairs are permitted provided that the model still conforms to the requirements of the rules and regulations.
- B.17.6. Each NAC shall process every model aircraft entered for a World or Continental Championships and shall issue for each model aircraft a model aircraft specification certificate, provided by the FAI. A sticker, also provided by the FAI or marking to the pattern of this sticker, shall appear on each model aircraft (except for Indoor and Scale model aircraft). Examples of how to fill out and handle the Model Aircraft Specification Certificate and Sticker are shown at Annexes B.1.a and B.1.b.
- B.17.7. Model aircraft not properly processed by their NAC, with FAI certificates and stickers, must be processed by the organiser at a cost of 8 Euro for each model.
- B.17.8. Except for Indoor and Scale, each model shall carry a model identification code (letters and/or numbers) and this must be recorded on the model specification certificate. The identification code is to appear on each part of the model aircraft (wing(s), tail, front and rear fuselage if detachable) so that the individual parts of a competitor's different models may be separately identified. The letters and/or numbers must be at least 10 mm high and clearly visible. The identification code of the nominated models will be recorded on the score card.
- B.17.9. Indoor free flight duration models must be processed before each flight to confirm that the model meets the dimensional and weight requirements of the class. Rubber motors are to be weighed before or after the flight to confirm that these are within the specification.
- B.17.10. Except for Indoor and Scale, each model must bear the nationality abbreviation of the International Olympic Committee and for Free Flight models the FAI license number or National Identification Number of the competitor. The letters or figures must be at least 25 mm high and appear at least once on each model (on the upper surface of a wing for Free Flight models). See Annex B.1 for examples and Annex B.2 for the list of nationality abbreviations.
- B.17.11. For categories F2 and class F3D all piston motors which might be used during the contest must be marked with an easily visible identification mark, details of which must be recorded at the time of checking the model. Motors which have been checked and recorded in this way may not be exchanged with other competitors.
- B.17.12. When, after official checking (for free flight, after registration of model specifications) a model is lost or damaged, the competitor shall have the right to present a further model and corresponding model specification certificate for checking up to one hour before the official starting time of the contest in that class. In any event, the competitor may have only the eligible number of models entered (see B.17.1) at the start of the contest.

- B.17.13. The organiser must appoint at least two processing officials, who will process at random the important model characteristics of at least 20% of competing models during the official contest time.
- B.17.14. Results are subject to the re-checking of the characteristics of the first, second and third place winning models.

B.17.15. Processing of Free Flight Model Aircraft - Class F1A, F1B, F1C, F1E, F1P.

- a) Model specification certificates and corresponding models must be presented on arrival at the time of registration for the event. These models will be clearly marked for identification by the organiser.
- b) Official processing of the model characteristics will not take place before the start of the contest.
- c) Before the start and during the contest, the competitors have the right to have launching cables (F1A) and motors (F1B) and swept volumes of motors (F1C, and F1P) officially checked.
- d) Before the start and during the contest, the competitors have the right to have the weight of their models checked.

B.18. PROTESTS

- B.18.1. All protests must be presented in writing to the Contest Director at the competition and must be accompanied by the deposit of a fee. The amount of this fee shall be the equivalent of 35 Euro. The deposit is returned only if the protest is upheld.

B.18.2. Time limit for lodging protests:

- a) Before the opening of the contest:
A protest against the validity of an entry, qualification of competitors, the contest rules, the flying and contest area, the processing of models, the judges or other contest officials, must be lodged at least one hour before the opening of the contest.
- b) During the contest: a protest against a decision of the judges or other contest officials or against an error or irregularity committed during an event by another competitor or team manager must be lodged immediately.
- c) After announcement of the results: any protest relating to the results must be submitted through the NAC within 15 days after announcement of the results by the organiser. If necessary this protest may be passed to the CIAM.

Note: A complaint may also be filed. The purpose of a complaint is to obtain a correction without the need to make a formal protest. See Sporting Code – General Section, 5.1

B.19. SAFETY PRECAUTIONS AND INSTRUCTIONS

The large majority of model flying today in most countries takes place as recreation rather than within a competition framework and sometimes on publicly accessible sites with little or no formal control. Any accident involving model aircraft may result in property damage, injury and possibly even death. Apart from the direct harm, a less obvious result is the poor image of model flying that comes from the media coverage of such incidents which leads to public antagonism and the loss of flying facilities.

While the following information is intended primarily for FAI competition flying, much of it can be applied both to national contests and recreational model flying.

B.19.1. Premise

It is of the utmost importance that all model fliers observe safety rules. Any accident caused by carelessness is a hindrance to the progress of model aviation.

Safety rules are not an obstacle to the enjoyment of model flying, they help to prove that model fliers are the responsible citizens they proclaim to be.

It is not a sign of intelligence to show one's own skill among spectators. The flier may know what he is doing but has no way of knowing what anyone else will do. So, it is to his personal benefit to make certain that no action on his part will result in an accident. It is therefore very important not to fly any model aircraft in competition or in the presence of spectators until it has been proved airworthy.

B.19.2. Competence

The following officials are competent to apply and enforce safety rules:

the Jury;
the Contest Judges;
the Contest Director;
the Circle Marshals;
the Flight Line Director;
the Processing Officials;
all officials of the Organising Body.

B.19.3. Prohibited

- a) Metal-bladed propellers and rotor blades;
- b) Repaired propellers and rotor blades;
- c) Improperly mounted engines;
- d) Knife-edge leading edges;
- e) Sharp spinners or propeller fasteners;
- f) Non shock-mounted radio equipment, where there is engine vibration;
- g) Any ballast or heavy parts subject to jettisoning;
- h) Any burning fuse that is not enclosed in a snuffer tube or similar device to retain and extinguish it;
- i) Propellers which fold forwards to have exposed propeller tips pointing forwards in the direction of flight.

B.19.4. Required

- a) The model should bear an identification of the owner.
- b) All spinners and other forward-facing metal or equally rigid projections should have a minimum radius of 5 mm.

B.19.5. Pre-flight Checks

Immediately before each flight, the flier must verify the actual condition and the proper functioning of all parts contributing to efficient and safe flight of the model and the proper fitting and fixation of the various parts, with special reference to engines and propellers.

Models that have not been tested and proven airworthy must not be flown in the presence of spectators. Endeavour to conduct all flights in a manner that avoids danger to spectators and other fliers.

- B.19.6. Immediately after the flier has launched his model, he must leave the starting area, remove his equipment, and in the case of gliders wind up his launching cable.

B.19.7. Flying Sites

It is imperative that all flying sites be situated sufficiently far from power lines.

The starting area must be carefully chosen in such a way that adequate safety to persons and property be granted. The points to be considered in this context are: wind strength and direction, relative position of buildings, runways, vehicle parking and spectator areas, and the area where the models are assumed to land after a normal flight, according to the wind.

Flying sites in the vicinity of an airport or airfield, especially along the landing path, can be chosen as contest venues only with the permission of the airport operator and in full compliance with its safety rules and requirements.

B.19.8. Penalties

All dangerous models must be excluded from a competition. For any action against the Safety Rules, the penalties listed in the Sporting Code General Section apply.

B.20. DISQUALIFICATION FROM THE CONTEST

- B.20.1. All competitors making use of a model, equipment or fuel which does not conform in all respects to the rules and regulations of the contest or which have not been verified by the organisers shall be disqualified from the contest.
- B.20.2. Disqualification must be applied after any action contrary to articles B.3.1.a) (unless specified otherwise in category rules), B.3.1b and B.3.1.c) or B.17.
- B.20.3. The Jury shall notify the Team Manager immediately and quote the reasons for disqualification.

B.21. FAI CHAMPIONSHIP TROPHIES

B.21.1. Custody

All trophies which have been adopted by the CIAM as awards to individual or team winners of Championships shall be considered to be in the custody of the FAI.

B.21.2. Ownership

Dependent upon the terms of presentation, trophies shall be considered the property of either the FAI or the donor. A schedule of ownership shall be maintained by the FAI Office.

B.21.3. Award

Trophies shall be awarded bi-annually. In those instances where for any reason a trophy is not awarded over a period of five years, custody of the trophy shall revert to the donor.

- B.21.4. For purposes of identification, the holder shall be the National Airports Control concerned.

B.21.5. Holders of the trophies shall be responsible for:

- a) Maintaining the trophy in good condition.
- b) Engraving the name of the winner and date of award in the manner established by previous winners.
- c) Insurance against loss for the period during which it is held.
- d) Delivery of the trophy to the organisers of the next Championships to the address and by the date requested by the organisers. Should no request be made, the trophy shall be delivered to the NAC of the organisers at least six weeks prior to the date of the Championships.
- e) The cost of transporting a trophy to the organisers of the Championships shall be responsibility of the NAC holding the trophy.

B.21.6. Collection of Trophies

B.21.6.1 Championship Trophies

- a) At the Championship, the Championship organiser, or a member of the FAI Jury, will use the trophy form to verify the status of the trophy and note the details, including identification data, of the new holder.
- b) The Championship organiser may ask the FAI office for a copy of the previous year's trophy form which contains the contact data of the current trophy holder.

B.21.6.2 World Cup Trophies

- a) At the transfer location, the World Cup organiser, or a member of the FAI Jury, will use the trophy form to verify the status of the trophy and note the details, including identification data, of the new holder.
- b) The World Cup organiser may ask the FAI office for a copy of the previous year's trophy form which contains the contact data of the current trophy holder.
- c) The World Cup Co-ordinator is responsible for the instigation of the trophy form procedure.

Note: see the instruction at the top of the World Cup trophy form.

cont/...

B.21.6.3 All CIAM Trophies

- a) The winner's NAC is responsible for the safe delivery of any trophy/trophies to the organiser at the next Championship.
- b) The completed form must be sent electronically to the FAI office with the electronic results (see B.5.5.). The FAI office will forward the trophy form to the CIAM Secretary.

Note i: The form is available for download from the CIAM website.

Note ii: A list showing the current holder of each of the presented perpetual FAI trophies will be published on the FAI website.

B.21.7. Registration of Trophies

The CIAM Bureau shall keep a master register of trophies listing the holders, donor and giving terms of presentation and acceptance. This register shall be maintained by the CIAM Secretary, and brought up to date each year, no later than at the CIAM Plenary Meeting.

B.21.8 Acceptance of Trophies

Donors of trophies considered to be "Perpetual" (i.e. remaining the property of the FAI or the donor) and proposed for award at Championships or World Cups shall declare their intent to the CIAM not later than the date of closure for the Plenary Meeting agenda each year. Acceptance of the trophy shall be conditional on a majority vote in favour by members of the CIAM.

B.21.9 Loss

In the event of loss or failure to award Championship trophies, organisers of Championships must present a statement of circumstances to the CIAM and propose replacement which shall be at the consideration of the donor of the original trophy and the CIAM.

ANNEX B.1.a

SAMPLE FAI SPECIFICATION CERTIFICATE

COMPETITOR Family Name: ANYONE **MODEL AIRCRAFT** Class: F2A
 First Name: JOHN Model Identification Code: 18B
 FAI Licence Number: National Identification Mark: SWE

STAMP OF NAC

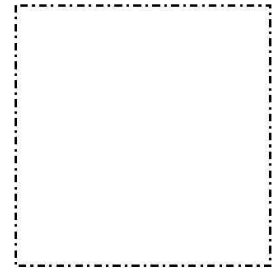

I certify that this model aircraft fulfils all requirements as specified in the FAI Sporting Code Section 4 and has been checked in accordance with the characteristics detailed below.

Signature: John Anyone (Competitor) Date: 12/06/07

Signature: Thomas Somebody.... (NAC Official/Team Manager)

To be completed by the Competitor and checked by the NAC

All classes except F1D, F1C, F2B, F3A, F3C, F4B, F4C

Model Aircraft Wing Area: 3.83 dm² **All classes except F1D**
 Model Aircraft Tailplane Area: 1.38 dm² Model Aircraft Weight:
 Model Aircraft Total Surface Area: 5.21 dm² 466 g

Data for this box to be taken from the appropriate volume of the Sporting Code

Weight Limits: Minimum: g Maximum: 521 g

(i) Weight limits are defined according to the class of model aircraft, either by the specific minimum/maximum weight or by the minimum/maximum loading of the surface area.

(ii) Minimum/maximum loading in classes F1C, F1E, F2A, F2D, F3J, F5B, F5D

Classes F1P, F2A & F3A

Wingspan: 999 mm

Class F3A

Fuselage Length: mm

Class F2A (Speed)

Minimum Surface Area for Maximum Swept Volume of Motor: 5 dm²

Class F2C (Team Race)

Fuselage Height:	<u> </u> mm	Scale Pilot Head:	<u> </u> mm
Fuselage Width:	<u> </u> mm	Height:	<u> </u> mm
Fuselage Cross Section:	<u> </u> cm ²	Length:	<u> </u> mm
Fuel Capacity:	<u> </u> cm ³	Width:	<u> </u> mm
Weight:	<u> </u> g	Wheel Diameter:	<u> </u> mm

Class F3D (Pylon Racing)

Fuselage Height:	<u> </u> mm	Wingspan:	<u> </u> mm
Fuselage Width:	<u> </u> mm	Wing Root Thickness:	<u> </u> mm
Fuselage Cross Section:	<u> </u> cm ²		

Classes F3C (Helicopters)

Sweep Area of Rotors: dm²
 Fixed Ancillary Surface (max 4% of the swept area of rotors): dm²
 Controllable Ancillary Surface (max 2% of the swept area of rotors): dm²

Class F5B (Electric Powered Motor Gliders)

Weight of Power Source: g Wheel Diameter: mm

Classes F1C, F1P, F2A, F2B, F2C, F2D, F3A, F3C, F3D, F4A, F4B, F4C

Permitted Maximum Swept Volume of the Piston Motor(s): 2.5 cm³

Principal checks to be completed by the organising NAC

Competitor Number:	<u> </u>
--------------------	-------------------

External Identification (✓)

Olympic Identity Marks (Except F1D, F4B, F4C)	<u> </u>
FAI Sticker Affixed (Except F1D, F4B, F4C)	<u> </u>
Model Aircraft Identification Code (on main parts) (Except F1D, F4B, F4C)	<u> </u>
Motors Marked F1C, F1P, F2A, F2C, F2D, F3D	<u> </u>

Measurements

Rubber Motors Weighed F1B	<u> </u> g
Wing Tip Guide Handle Spacing F2A	<u> </u> mm
Fuel Capacity F2C	<u> </u> cm ³
Nose Radius F3A, F3B, F3J, F3K	<u> </u> mm
Flying Weight Dry	<u> </u> g
Weight of Power Source F5B	<u> </u> g

Special Requirements (✓)

Motor Cowling Approved F2C & F3D	<u> </u>
Silencer Fitted F2A, F2B, F2D, F3A, F3D	<u> </u>
Fuel Shut-off Fitted F2A, F2D, F3D	<u> </u>
Exhaust Outlet Checked F2A & F2D	<u> </u>
Intake Size Checked F2D	<u> </u>

CHECKED BY

Sign:
 Sign:
 Date:

STAMP OF ORGANISING NAC



ANNEX B.1.b

EXAMPLES OF NATIONAL IDENTIFICATION MARKS

Ref. Section 4B paragraph B.17.10 and Annex B.2.

SUI

(Switzerland)

NED

(The Netherlands)

The National Identification mark shall appear on the model aircraft at least once, and must be at least 25 mm high.

EXAMPLE OF THE FAI MODEL STICKER WITH SAMPLE COMPETITOR DETAILS COMPLETED

Ref: Section 4B, Paragraphs B.17.6, B.17.8, B.17.10

FAI	LICENCE NUMBER:	<i>13579</i>
	NATIONAL IDENTIFICATION MARK & NUMBER	<i>GBR</i>
	COMPETITOR NAME	<i>A N O T H E R</i>
	MODEL AIRCRAFT IDENTIFICATION CODE	<i>specific to competitor</i>

- 1 The sticker is shown larger than the actual size of 65mm x 34mm.
- 2 Only one sticker per model required (B.17.6)
- 3 However, the model aircraft identification code shall appear on each detachable main part of the model and be at least 10mm high. (B.17.8)
- 4 The national identification mark of the International Olympic Committee must appear at least once on each model and be at least 25mm high. (B.17.10).
- 5 Competitors that have been issued with an FAI sporting licence direct from the FAI must put "FAI" as their national identification mark.

ANNEX B.2

NATIONAL IDENTIFICATION MARKS

This listing does not imply that the countries listed are current FAI member organisations.

AFG	Afghanistan	CIV	Cote d'Ivoire
AHO	Netherlands Antilles	CMR	Cameroon
ALB	Albania	COD	Democratic Republic of the Congo
ALG	Algeria	COK	Cook Islands
AND	Andorra	COL	Colombia
ANG	Angola	COM	Comoros
ANT	Antigua and Barbuda	CPV	Cape Verde
ARG	Argentina	CRC	Costa Rica
ARM	Armenia	CRO	Croatia
ARU	Aruba	CUB	Cuba
ASA	American Samoa	CYP	Cyprus
AUS	Australia	CZE	Czech Republic
AUT	Austria	DEN	Denmark
AZE	Azerbaijan	DJI	Djibouti
BAH	Bahamas	DMA	Dominica
BAN	Bangladesh	DOM	Dominican Republic
BAR	Barbados	ECU	Ecuador
BDI	Burundi	EGY	Egypt
BEL	Belgium	ERI	Eritrea
BEN	Benin	ESA	El Salvador
BER	Bermuda	ESP	Spain
BHU	Bhutan	EST	Estonia
BIH	Bosnia and Herzegovina	ETH	Ethiopia
BIZ	Belize	FIJ	Fiji
BLR	Belarus	FIN	Finland
BOL	Bolivia	FRA	France
BOT	Botswana	FSM	Federated States of Micronesia
BRA	Brazil	GAB	Gabon
BRN	Bahrain	GAM	Gambia
BRU	Brunei Darussalam	GBR	United Kingdom
BUL	Bulgaria	GBS	Guinea-Bissau
BUR	Burkina Faso	GEO	Georgia
CAF	Central African Republic	GEQ	Equatorial Guinea
CAM	Cambodia	GER	Germany
CAN	Canada	GHA	Ghana
CAY	Cayman Islands	GRE	Greece
CGO	Congo	GRN	Grenada
CHA	Chad	GUA	Guatemala
CHI	Chile	GUI	Guinea
CHN	People's Republic of China	GUM	Guam

GUY	Guyana	MON	Monaco
HAI	Haiti	MOZ	Mozambique
HKG	Hong Kong, China	MRI	Mauritius
HON	Honduras	MTN	Mauritania
HUN	Hungary	MYA	Myanmar
INA	Indonesia	NAM	Namibia
IND	India	NCA	Nicaragua
IRI	Islamic Republic of Iran	NED	Netherlands
IRL	Ireland	NEP	Nepal
IRQ	Iraq	NGR	Nigeria
ISL	Iceland	NIG	Niger
ISR	Israel	NOR	Norway
ISV	Virgin Islands	NRU	Nauru
ITA	Italy	NZL	New Zealand
IVB	British Virgin Islands	OMA	Oman
JAM	Jamaica	PAK	Pakistan
JOR	Jordan	PAN	Panama
JPN	Japan	PAR	Paraguay
KAZ	Kazakhstan	PER	Peru
KEN	Kenya	PHI	Philippines
KGZ	Kyrgyzstan	PLE	Palestine
KOR	Korea	PLW	Palau
KSA	Saudi Arabia	PNG	Papua New Guinea
KUW	Kuwait	POL	Poland
LAO	Laos People's Democratic Republic	POR	Portugal
LAT	Latvia	PRK	Democratic People's Republic of Korea
LBA	Libyan Arab Jamahiriya	PUR	Puerto Rico
LBR	Liberia	QAT	Qatar
LCA	Saint Lucia	ROU	Romania
LES	Lesotho	RSA	South Africa
LIB	Lebanon	RUS	Russia
LIE	Liechtenstein	RWA	Rwanda
LTU	Lithuania	SAM	Samoa
LUX	Luxembourg	SEN	Senegal
MAD	Madagascar	SEY	Seychelles
MAR	Morocco	SIN	Singapore
MAS	Malaysia	SKN	Saint Kitts and Nevis
MAW	Malawi	SLE	Sierra Leone
MDA	Republic of Moldova	SLO	Slovenia
MDV	Maldives	SMR	San Marino
MEX	Mexico	SOL	Solomon Islands
MGL	Mongolia	SOM	Somalia
MKD	Former Yugoslav Republic of Macedonia	SRB	Serbia
MLI	Mali	SRI	Sri Lanka
MLT	Malta	STP	Sao Tome and Principe
MNE	Montenegro	SUD	Sudan

SUI	Switzerland
SUR	Suriname
SVK	Slovakia
SWE	Sweden
SWZ	Swaziland
SYR	Syrian Arab Republic
TAN	United Republic of Tanzania
TGA	Tonga
THA	Thailand
TJK	Tajikistan
TKM	Turkmenistan
TOG	Togo
TPE	Chinese Taipei
TRI	Trinidad and Tobago
TUN	Tunisia
TUR	Turkey
UAE	United Arab Emirates
UGA	Uganda
UKR	Ukraine
URU	Uruguay
USA	United States of America
UZB	Uzbekistan
VAN	Vanuatu
VEN	Venezuela
VIE	Vietnam
VIN	Saint Vincent and the Grenadines
YEM	Yemen
ZAM	Zambia
ZIM	Zimbabwe

ANNEX B.3

GENERAL ORGANISATION OF A WORLD CHAMPIONSHIP

1. **Time to Elapse:** 12 months. **Planning:** Models Commission of National Airports Control or equivalent investigates sites, accommodation and business management of potential Championships including sponsorship. Produce estimates based upon number of competitors, administrators, supporting officials, press, etc.
Action: Contact with airfield authorities and possible sponsors.
2. **Time to Elapse:** 11 months. **Planning:** Specialist committee created for organisation (Chairman, FAI Delegate, Treasurer, Event specialists and Contest Director). Financial estimates produced. Decision made to proceed with an offer to host event.
Action: FAI Delegate briefed to present proposition to CIAM.
3. **Time to Elapse:** 9 months. **Planning:** Proposition made to CIAM Plenary Meeting, naming location, accommodation facilities, esteemed fees, period of meeting, associated events.
Action: CIAM accepts offer, approves associated events and fees on estimate.
4. **Time to elapse:** 8 months. **Planning:** Decision made on contest site plan. Liaison Committee formed with site officials e.g. FAI Delegate, Chairman, Vice-Chairman, Treasurer and Contest Director with Airfield or Contest site administration officials. Site measured and plan of proposed area prepared including flight areas and buildings.
Action: Meeting of preliminary planning personnel on location; Minutes and data circulated to all organising personnel.
5. **Time to Elapse:** 7 months. **Planning:** Full Budget prepared. Based on quotation for accommodation, feeding, travel costs of Judges, equipment, purchase, printing, hire of materials and other expenses. First publicity release and advance information memorandum prepared. Cost of entry fee finalised. Programme visualised and advertisement support solicited.
Action: Issue of invitation to all member NACs of FAI with memorandum containing rules for event(s).
6. **Time to Elapse:** 6 months. **Planning:** Jury, Judges and Timekeepers nominated. Fully detailed site plan prepared by Contest Director. Firm duties allocated for:
 - (1) Liaison with Site officials
 - (2) Field Organisation
 - (3) Printing and Publicity
 - (4) Finance
 - (5) Preparation of special equipment
 - (6) Accommodation.**Action:** Report to CIAM Bureau meeting by FAI delegate. Judges and reserves confirmed. Method of judging approved by CIAM Bureau.
7. **Time to Elapse:** 5 months. **Planning:** Meeting with site officials. Confirming accommodation available. Local town accommodation reserved for visitors, married personnel, etc. Flying area surface inspected, contest layout planned for ceremonies, pit areas, processing bays. Event emblem and programme layout defined. Second publicity releases issued. All Jury and Judges announced. Quotes accepted for public service toilets, field refreshments, etc. Banquet and prize giving planned.
Action: All officials active in procurement of material, particularly publicity officer, FAI delegate and Programme Producers.
8. **Time to elapse:** 4 months. **Planning:** Personnel for each event nominated or chosen from volunteers in NAC. Requirements as follows: Processing team; Director for each event circle; timekeepers; scorers; lap counters; messengers; monitors.
Action: All personnel advised of duties and obligations. Work delegated to spread responsibility.
9. **Time to Elapse:** 3 months. **Planning:** First entries acknowledged. By information memorandum, offering travel advice, cost and request for notice of arrival. Programme and contest recording printing ordered. Souvenir plaques ordered. Tents ordered. Early arrivals anticipated. Auxiliary events planned - exhibition, etc. Judges' travel tickets issued. Local practice area selected. Third Press release issued concerning entries.
Action: By FAI Delegate and Publicity Officer.

10. **Time to Elapse:** 2 months. **Planning:** Entries officially complete. Numbers finalised for on-site and off-base accommodation. Supporters accepted where possible. Programme copy to printer. Delivery dates finalised for all equipment. Numbered waistcoats, flags, awards prepared. Final directive issued to all personnel stating responsibilities and financial obligations. All primary officials to be fully advised of each other's responsibilities. Daily programme prepared and issued to all competing NACs.
Action: Officers for accommodation, publicity. Contest director active in securing all arrangements.
11. **Time to Elapse:** 1 month. **Planning:** Field equipment tested. Lap or score indicators checked. Delivery of barriers or wire mesh. Tables and chairs secured, work benches, spectator stands. Local transport secured. Accommodation fully planned. Programme passed for printing. Contest record cards delivered and prepared. Score boards stencilled. Full schedules of names for competitors, officials, supporters, VIPs and observers prepared with lapel badges for each. (Colour coded, White - Competitors, Yellow - Judges, Jury, Officials; Brown - General Staff; Green - Important persons and Chief Officials). Souvenirs allocated (brief cases) after making up. Fuels ordered including extra components for visiting entries unable to travel with fuels. Litter sacks ordered. Traffic control planned with highway authorities. Exhibition planned.
Action: All officials active. Full exchange of information between all concerned.
12. **Time to Elapse:** 3 weeks. **Planning:** Final Liaison with Site Officials, catering and local authorities. Programmes delivered. All personnel involved in duties other than field events briefed by marshals and event directors as necessary. Fourth press release issued with photographs. Banquet and prizegiving to be finalised.
Action: Contest Director, Accommodation and Publicity Officer.
13. **Time to Elapse:** 2 weeks. **Planning:** Flight areas marked and finally prepared. Directions issued to Main Line Railway stations to guide visitors. Treasurer accounts for advance payment of fees. Transport confirmed from nearest rail station. Bedding set aside. Banner, flags and poles prepared. Numbered waistcoats, souvenir plaques, posters delivered and distribution planned.
Action: Contest Director, Accommodation, Treasurer, Publicity Officer.
14. **Time to Elapse:** 1 week. **Planning:** Advance party on location. To receive and erect tents, tables, barriers and airfield equipment. All scoring systems, loud speakers, light observation platforms positioned. All equipment tested. Ropes, stakes and litter sack positions planned. Special contest requirements anticipated. Early arrivals diverted to local areas. Fifth press release for local papers.
Action: By Contest Director and staff. Publicity Officer.
15. **Time to Elapse:** 2 days. **Planning:** All equipment on location including trophies and printed matter. Ropes and stakes established, public areas controlled. Toilets erected, exhibition staged. Sixth and final press releases issued. Advance radio, TV and photographic reception for publicity arranged. Processing team fully briefed and reception finally planned.
Action: All officers active on location.
16. **Time to Elapse:** 1 day. **Planning:** Rehearsals. Models processed, specification certificates and FAI licences collected. Briefing of all officials, dummy event to establish standards, for all judges who are pre-briefed, trained through practice flights, then debriefed with analysis of scores. Timekeepers checked for proficiency. All circuits finally prepared. Draw cards and lists prepared for order of flying. Issue of memorandum detailing all decisions of contest management meeting.
Action: All officials, judges, jury, team managers.

THE INTERNATIONAL CONTEST THEN TAKES PLACE IN ACCORDANCE WITH THE SPORTING CODE.

17. **Time to Elapse:** 2 days. **Planning:** Site Clearance. Rearguard party dispatches all loaned equipment, clears accommodation area, secures all found property, lists liabilities, breakages, etc.
Action: Rearguard and contest director.

NOTE for WCh: Ranking - International Team Classification - Complete three competitor teams are ranked ahead of two competitor teams, which are in turn ranked ahead of single competitor teams.

Fuel - See B.5.6.

INFORMATION TO CIAM BUREAU

- 1) The actual situation, date for entries etc.
- 2) Undertaken preparations
- 3) Contest organisation:
 - FAI Jury
 - Contest management
 - Main officials and their duties

cont/...

Arrival, how to find the place
 Lodgings
 Camping facilities
 Hotels
 Parking
 Meals
 Canteen, if any
 Depots
 Tracks
 Conveniences
 Practice flights
 Processing
 Information
 Public Relations
 Emergency, first aid
 Insurance
 Spectators
 Programme

4) Distribution of maps of the contest area.

ADMINISTRATION & ORGANISATION

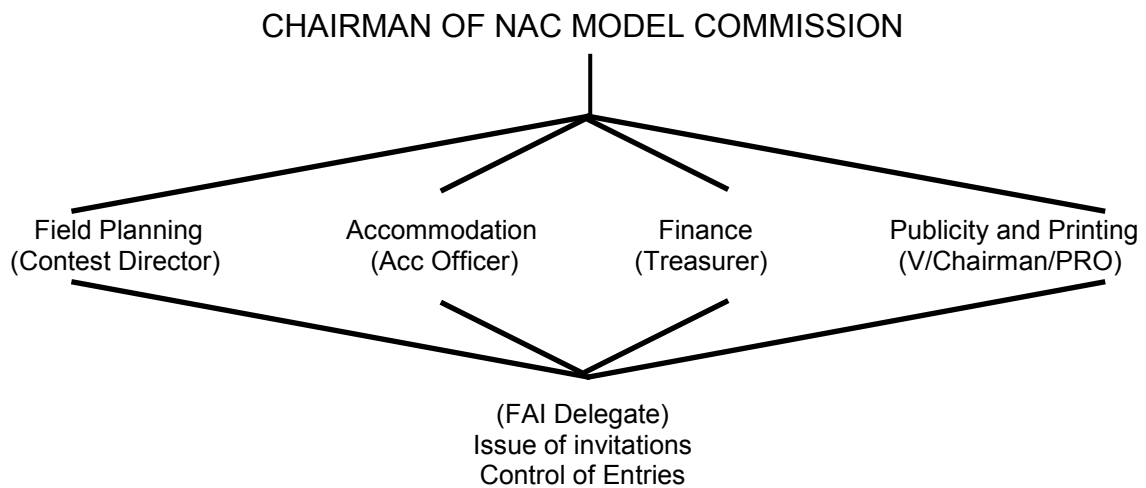

cont/...

EVENT DIRECTION

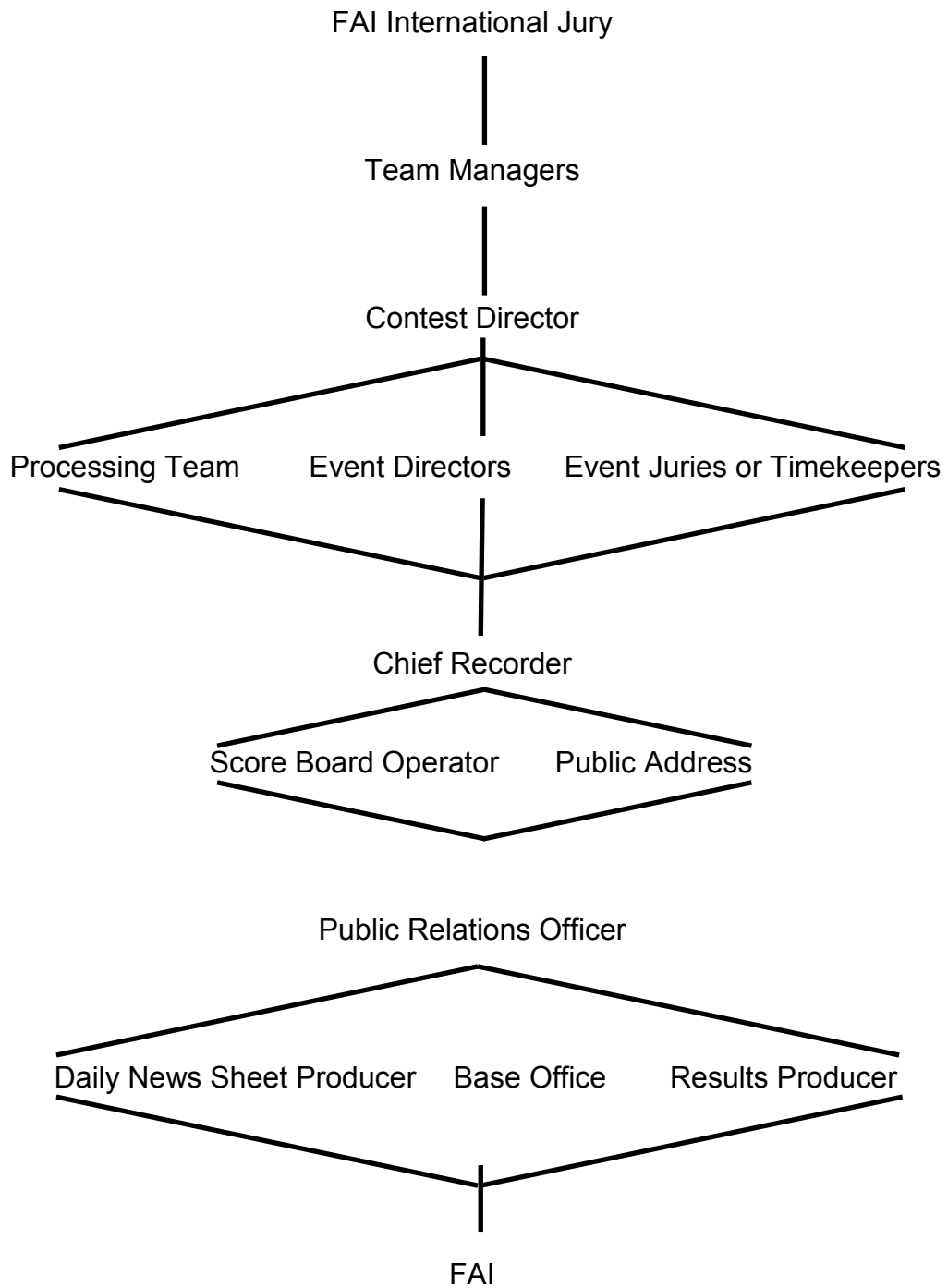

It is acknowledged that this memorandum can only be regarded as a general guide and is subject to variation according to the type of contest, venue and local conditions.

SECTION 4C – MODEL AIRCRAFT

PART ONE - GENERAL REGULATIONS FOR MODEL AIRCRAFT

1.1. GENERAL DEFINITION OF MODEL AIRCRAFT

A model aircraft is an aircraft of limited dimensions, with or without a propulsion device, not able to carry a human being and to be used for competition, sport or recreational purposes

For the whole flight, a radio-controlled model aircraft shall be in the direct control of the flier, via a transmitter, and in the flier's sight other than for momentary periods.

For control line model aircraft, the flier must physically hold the control line handle and control the model aircraft himself.

Free flight model aircraft must be launched by the flier and must not be controlled remotely during the flight other than to stop the motor and/or to terminate the flight

A model aircraft shall not be equipped with any device that allows it to be flown automatically to a selected location.

In the case of record attempts conducted under Part 2, the claimant(s) shall confirm that the submitted record claim is for a model aircraft record as noted in Table III.

1.2. GENERAL CHARACTERISTICS OF MODEL AIRCRAFT

Unless otherwise stated, model aircraft shall meet the following general specifications:

Maximum flying weight with fuel	25 kg
Maximum surface area	500 dm ²
Maximum loading	250 g/dm ²
Maximum swept volume of piston motor(s)	250 cm ³
Electric Motors power source max. no load voltage	72 volts
Maximum total thrust of turbines	25kg (250 Newton)

Noise limits shall be applied to powered model aircraft categories, with 96 dB(A) at 3 metres for any category which does not have approval for any other noise rule. Specific noise measuring procedures are to be developed by each Sub-committee for its category.

Noise limits do not apply to model aircraft with electric motors or equipped with turbines.

1.3. CLASSIFICATION OF MODEL AIRCRAFT

1.3.1. Category F1 - Free Flight

This is a flight during which there exists no physical connection between the model aircraft and the competitor or his helper. Radio control functions are allowed only when specifically stated in the rules for the relevant class. Closed loop control systems with active sensors and operating aerodynamic flight controls are not allowed, except for steering in F1E.

Class:	F1A	- GLIDERS
	F1B	- MODEL AIRCRAFT WITH EXTENSIBLE MOTORS "Wakefield"
	F1C	- POWER MODEL AIRCRAFT
	F1D	- INDOOR MODEL AIRCRAFT
	F1E	- GLIDERS WITH AUTOMATIC STEERING
	F1G	- MODEL AIRCRAFT WITH EXTENSIBLE MOTORS "Coupe d'Hiver"
	F1H	- GLIDERS
	F1J	- POWER MODEL AIRCRAFT
	F1K	- MODEL AIRCRAFT WITH CO ₂ ENGINES

cont/...

- F1L - INDOOR EZB MODEL AIRCRAFT
- F1M - INDOOR BEGINNER'S CLASS
- F1N - INDOOR HAND LAUNCH GLIDERS
- F1P - POWER MODEL AIRCRAFT
- F1Q - ELECTRIC POWER MODEL AIRCRAFT
- F1R - INDOOR MICRO35 MODEL AIRCRAFT

1.3.2 **Category F2 - Control Line Circular Flight**

This is a flight during which the model aircraft is manoeuvred by control surfaces in attitude and altitude by the flier on the ground by means of one or more inextensible wires or cables directly connected to the model aircraft. Devices in which the control wires or cables are held in the hand or connected to a central pivot may be used. No other means of controlling the model or the engine(s) may be employed during the take-off and flight except that exercised by the flier through the line or lines.

A safety strap connecting the competitor's wrist to the control handle must be provided by the competitor and used during all flights. A pull test shall be applied separately to the safety strap when attached to the competitor's wrist. This pull test will be applied according to each class specification concerning the lines' pull test.

- Class:
- F2A - SPEED MODEL AIRCRAFT
 - F2B - AEROBATIC MODEL AIRCRAFT
 - F2C - TEAM RACING MODEL AIRCRAFT
 - F2D - COMBAT MODEL AIRCRAFT
 - F2E - COMBAT MODEL AIRCRAFT WITH COMPRESSION IGNITION ENGINES
 - F2F - DIESEL PROFILE RACING MODEL AIRCRAFT
 - F2G - ELECTRIC SPEED

1.3.3. **Category F3 - Radio Controlled Flight**

This is a flight during which the model aircraft is manoeuvred by control surface(s) in attitude, direction and altitude by the flier on the ground using radio control.

- Class:
- F3A - AEROBATIC POWER MODEL AIRCRAFT
 - F3B - MULTI-TASK GLIDERS
 - F3C - HELICOPTERS
 - F3D - PYLON RACERS
 - F3F - SLOPE SOARING GLIDERS
 - F3H - SOARING CROSS COUNTRY RACING GLIDERS
 - F3J - THERMAL DURATION GLIDERS
 - F3K - RADIO CONTROLLED HAND LAUNCHED GLIDERS
 - F3M - LARGE AEROBATIC POWER MODEL AIRCRAFT
 - F3N - HELICOPTERS FREESTYLE
 - F3P - INDOOR AEROBATICS
 - F3Q - AERO TOW SOARING GLIDERS

1.3.4. **Category F4 - Scale Model Aircraft**

A scale model shall be a scaled down replica of a heavier-than-air man-carrying aircraft.

- Class:
- F4A - FREE FLIGHT FLYING SCALE MODEL AIRCRAFT
 - F4B - CONTROL LINE FLYING SCALE MODEL AIRCRAFT
 - F4C - RADIO CONTROLLED FLYING SCALE MODEL AIRCRAFT
 - F4D - FREE FLIGHT INDOOR SCALE MODEL AIRCRAFT; Extensible motors
 - F4E - FREE FLIGHT INDOOR SCALE MODEL AIRCRAFT; CO₂ or electric motors
 - F4F - FREE FLIGHT INDOOR SCALE MODEL AIRCRAFT; Peanut formula

cont/...

- F4G - LARGE SCALE MODEL AIRCRAFT
- F4H - STAND-OFF SCALE MODEL AIRCRAFT

1.3.5. **Category F5 - Radio Controlled Electric Powered Flight**

This category is divided into the following classes:

- Class: F5A - AEROBATIC MODEL AIRCRAFT
- F5B - MOTOR GLIDERS
- F5C - HELICOPTERS
- F5D - PYLON RACERS
- F5E - SOLAR MODEL AIRCRAFT
- F5F - 10 CELL MOTOR GLIDERS
- F5G - RADIO CONTROLLED ELECTRIC BIG GLIDERS

1.3.6 **Category F6 - Airsports Promotion**

This category is divided into the following classes:

- Class: F6A - ARTISTIC AEROBATICS
- F6B - AEROMUSICALS
- F6D - HAND THROWN GLIDERS

1.3.7. **Category F7 - Radio Controlled Aerostats**

This category contains the following class:

- Class: F7A - HOT AIR BALLOONS

1.4 **DEFINITIONS OF EXPRESSIONS USED FOR MODEL SPECIFICATIONS AND RULES**

1.4.1. **Surface Area**

The surface area includes the total surface of the wings and that of the horizontal or oblique stabilising surface or surfaces. The surfaces taken for calculation are the orthogonal projection on to a horizontal plane of the surfaces in question with each surface at zero incidences.

When wings or stabilising surfaces are built into the fuselage of the model aircraft the surface taken into account shall include that area contained within the normal contours of the flight surfaces extended so as to meet at the plane of symmetry of the model.

1.4.2. **Weight**

The weight taken to determine the minimum loading and minimum weight is that of the complete model aircraft in flying order but without fuel.

1.4.3. **Loading**

When loading rules are applied the loading shall be defined at the weight in grams per square decimetre of surface area.

1.4.4 **Ballast**

When it is necessary to use supplementary ballast to obtain the stipulated weight or adjust the position of the centre of gravity, this must be located internally in the model and fixed in a permanent manner. Its position must be inspected and approved by a recognised official after insertion. When movable ballast is used to adjust the position of the centre of gravity, the model must be of the weight specified without the movable ballast.

1.4.5. **Wingspan**

Wingspan is the maximum distance between two points terminating the wing.

1.4.6. **Extensible Motor**

Motor in which the energy is obtained by the torsion or extension of strands of elastic material.

1.4.7. **Piston Motor**

Motors in which the energy is obtained by the combustion or expansion of a fluid acting on one or more reciprocating or rotary pistons.

1.4.8. **Glow Plug Motor**

A glow plug motor uses a continuously incandescent element to provide ignition.

1.4.9. **Compression Ignition Motor**

A compression ignition motor is one in which the charge is ignited solely by the effect of compression. This may include a mechanical system specially provided to control compression when the engine is operating.

1.4.10. **Jet Reaction Motor**

Motor in which the energy is obtained by a combustion of a solid, liquid or gaseous fuel, or by the expansion of a fluid acting on a rotating or pulsating member. In the case of model aircraft driven by reaction motors, the following supplementary characteristics are imposed:

Maximum outside diameter of pulse-jet combustion chamber: 80 mm.

1.4.11. **Hand Launching**

This is effected by hand, the competitor or helper standing on the ground.

1.4.12. **Take-off**

The model must rise from the ground or water in the correct manner and, other than for Control Line, without any help from the flier or mechanic

1.4.13. **Landing**

The model is considered to have landed when it has first touched ground or water, or definitely terminated its forward movement.

1.4.14. **Seaplane**

This is a model aircraft which must take off from water, but without obligation to land on the water at the termination of the flight. Prior to the take-off, a flotation test of one minute must be imposed on each model during which it must float on the surface without external aid in normal take-off position.

1.4.15. **Helicopters**

A helicopter is a heavier than air model aircraft which derives all of its lift and horizontal propulsion from (a) power driven rotor system(s) rotating about a nominally vertical axis (or axes).

Fixed horizontal supporting surfaces up to 4% of the swept area of the rotor(s) are permitted. A fixed or controllable horizontal stabiliser up to 2% of the swept area of the rotor(s) is permitted. Ground effect machines (hovercraft), convertiplanes or aircraft which hover by means of propeller slipstream(s) deflected downward are not considered to be helicopters.

Specifications

Area: Maximum swept area of the lifting rotor(s) counting only once any area superimposed areas: 300 dm², except for coaxial helicopters whose rotors are farther than one rotor radius apart, in which case the total area of both rotors is counted.

Weight: Maximum 5 kg with fuel.

Piston motor swept volume: Maximum 10 cm³.

Rubber motor: No restrictions.

Note: Metal bladed rotors are prohibited.

1.4.16. Swept Volume

a) Reciprocating engine

Swept volume is calculated as:

Swept piston area x stroke = swept volume

Swept piston area is calculated by measuring the bore of the liner at the top dead centre.

The calculation of volume shall be truncated to two decimal places (0,01 cm³)

b) Rotary engine

Swept volume is calculated as:

$$0,325(C^2 - D^2).b$$

For the meaning of the letters see the figure overleaf

DISPLACEMENT CALCULATION OF A ROTARY PISTON ENGINE

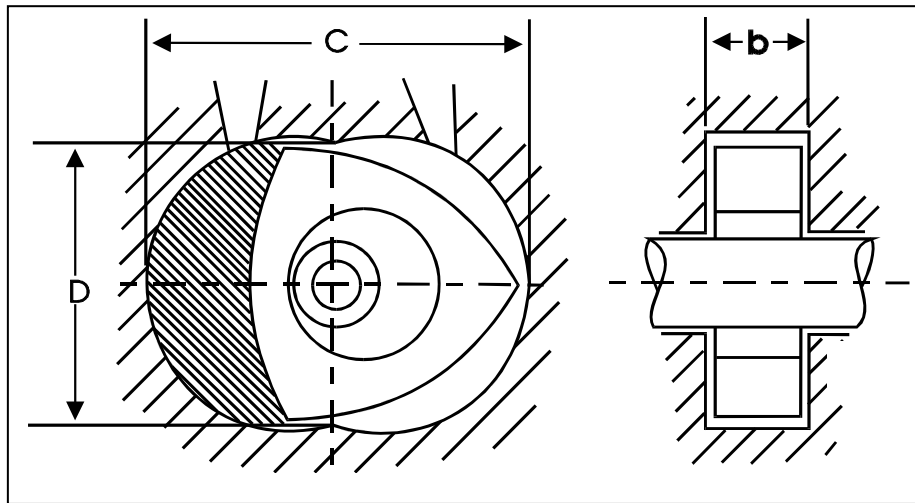

ANNEX 1.1

WORLD CHAMPIONSHIP EVENTS FOR MODEL AIRCRAFT

The following events are recognised as World Championships for model aircraft (2008):

1. FF category for Seniors:

- a) F1A Gliders
- b) F1B Model aircraft with extensible motors
- c) F1C Model aircraft with piston motors
- d) F1D Indoor model aircraft
- e) F1E Gliders with automatic steering

2. CL category for Seniors & Juniors

- a) F2A Speed model aircraft
- b) F2B Aerobatic model aircraft
- c) F2C Team racing model aircraft
- d) F2D Combat model aircraft

3. RC category for Seniors

- a) F3J Radio controlled thermal duration gliders
- b) F3K Radio controlled hand launch gliders

4. RC category for Seniors & Juniors

- a) F3A Radio controlled aerobatic model aircraft
- b) F3B Radio controlled multi-task gliders
- c) F3C Radio controlled helicopters
- d) F3D Radio controlled pylon racing model aircraft
- e) F3F Radio controlled pylon racing model aircraft
- f) F5B Radio controlled electric powered gliders
- g) F5D Radio controlled electric powered pylon racers

5. Scale category for Seniors & Juniors:

- a) F4C Radio controlled model aircraft

6. Free Flight category for Juniors:

- a) F1A Gliders
- b) F1B Model aircraft with extensible motors
- c) F1D Indoor model aircraft
- d) F1E Gliders with automatic steering
- e) F1P Model aircraft with piston motors

7. RC category for Juniors:

- a) F3J Radio controlled thermal duration gliders
- b) F3K Radio controlled hand launch gliders

PART TWO - RECORDS

2.1. WORLD CLASS RECORDS:

2.1.1. The FAI recognises World class records in the categories of model aircraft listed in Table I.

2.1.2. Holder(s) of Records.

A World record may belong to one person or a team. Where the record is in the name of more than one person, FAI will list those persons in alphabetical order, unless otherwise directed by the claimants' NAC.

2.1.3. Builder of the Model Aircraft

In all records, the claimant(s) must be the builder(s) of the model aircraft flown in the attempt, except where the competition rules for the class exempt that class from rule B.3.1.a). The claimant(s) has/have to confirm this by his/their signature on form "Table II, Application for Record Confirmation".

2.1.4. Categories of World Records

There are three categories of World Records, viz:

- 1) Records performed with special record model aircraft under the specifications given in paragraph 2.2. (Open Records)
- 2) Records performed with model aircraft built to competition specification but with flights not necessarily in a competition (Specific Model Aircraft). These records can be set in classes F1D, F1L, F1M and F1N and in these classes the record may belong only to one person, not a team.
- 3) Records performed in regular competitions with model aircraft and competitions defined in Sporting Code Section 4C, parts 1, 2, 3, 4 and 5 (Competition Records).

In Free Flight competition, duration records can be set in classes F1D and F1L and in these classes the record may belong only to one person, not a team.

In Control Line competition the following records may be set only in World or Continental Championships:

- (a) speed records in class F2A (sub-class 134 in Table I);
- (b) race time records in class F2C (sub-classes 136 & 137 in Table I).

In classes F3D and F5D, records may be set only in World or Continental Championships.

2.1.5. Claimants

Claimants shall refer to the FAI Sporting Code General Section 2.3 and Chapters 6 & 7 as well as the whole of this Part Two - Records section of Volume ABR Section 4C.

2.2. GENERAL SPECIFICATIONS OF MODEL AIRCRAFT FOR RECORD ATTEMPTS:

2.2.1. Weight:

For records mentioned under 2.1.4, item 1), the total weight of the model aircraft in flying order, with fuel when carried, shall not exceed 5.00 kg. The maximum total weight in flying order with fuel of a helicopter shall not exceed 6.00 kg. For records in regular competition under 2.1.4. item 3), the model aircraft must comply with the specifications required for the class concerned.

No refuelling shall be permitted after the model aircraft is airborne during any record attempt.

2.2.2. Motive Power:

The total swept volume of the piston(s) of the motor(s) shall not exceed 10 cm³. Pulse-jet reaction motor(s) are not permitted except for circular flight (record No. 135).

Power sources for electro models:

cont/...

There will be three different possibilities of power sources:

F5 - "S" With rechargeable sources of current only (secondary elements).

F5 - "SOL" Solar cells only permitted.

F5 - "COMB" All sources of current are allowed. All kinds of combinations are expressly allowed. There must be a minimum of two sources of current.

No connection between the source of current aboard the record model aircraft and the ground, or to another model aircraft or flying object is allowed.

There are no restrictions on the weight of extensible motors in model aircraft records except in the case of competition records.

Metal bladed propellers are not permitted.

2.2.3. Surface Area:

a) Fixed wing aircraft

(1) For fixed wing aircraft the maximum surface area shall be 150 dm².

(2) See 1.4.1

b) Rotary wing aircraft

See 1.4.15

2.2.4. Surface Loading:

For free flight model aircraft, the loading on the surface area must be between 12 g/dm² and 50 g/dm². For radio control model aircraft, the loading of the surface area must not exceed 75 g/dm². For control line model aircraft, the loading of the surface area must not exceed 100 g/dm². There are no area loading requirements or wing span restrictions for indoor model aircraft for record purposes.

2.2.5. Controlling the Model

For radio controlled model aircraft or gliders in F3 or F5 record attempts, the pilot must be in direct control of the model aircraft via a transmitter for the whole of the flight.

2.2.6. Sight of the Model

For radio controlled model aircraft or gliders in F3 or F5 record attempts, the model aircraft must be in the pilot's sight for the whole of the flight other than for momentary periods.

2.2.7. Launching:

The model aircraft may be hand-launched or take off from the ground for record attempts in any category except seaplanes, the launcher standing on the ground. Aerotow is not permitted. Seaplanes must take off from a water surface.

For free flight a glider is launched by means of a cable of maximum 100 m in length. For radio controlled flight a glider is launched by means of a cable of 300 m maximum length. Launching of a glider may be carried out with the help of various devices such as winches, single or multiple pulley trains, or by running etc. To facilitate observation and timing the cable must be equipped with a pennant having a minimum area of 2,5 dm². All types of auxiliary stabilising devices are forbidden.

A parachute may be substituted for the pennant provided it is not attached to the glider and remains packed and inactive until the release of the cable.

The claimant, or a member of the team, must operate the launching device and must be standing on the ground, except for R/C gliders where an assistant may operate the device.

All freedom of action and movement is permitted to allow the best use of the cable length.

Auxiliary take-off devices, such as a cart or a dolly undercarriage are permitted for all model aircraft except seaplanes. No means of auxiliary power is permitted on such devices. The device may become airborne and subsequently ejected.

For seaplanes, the landing gear must remain attached to the model throughout the flight.

2.2.8. Point of Landing:

The point where the model first touches the ground or water shall be considered the Point of Landing. It is not required that seaplanes land on water.

2.2.9. Jettisoning or Loss of Parts:

The voluntary or involuntary jettisoning of any part of the model aircraft, except auxiliary take-off devices, during the flight, is forbidden.

2.2.10. Assistant Pilots:

Following Rule 2.1.2, in case of a team effort, each member of the team may act as pilot during the attempt.

Note: In the event that it is desired that a distance or duration record shall be listed in a single name only, an assistant pilot may be utilised after two hours from the start of the flight, up to a maximum of 10% of the total flight time recorded.

2.2.11. Difference between Consecutive Records:

There is no minimum figure by which the old record should be exceeded.

2.2.12. Officials and Observers:

The head official shall be delegated by the National Airports Control of the country where the attempt is made and the attempt must be witnessed by a minimum of 2 additional observers who are approved by that National Airports Control.

2.2.13. Flying Site

Duration and Distance in Closed Circuit records for powered model aircraft (any power source) shall be made without the benefit of slope lift, rotors, lee waves and similar forms of lift. The land within a sufficient distance from the course must be free from objects which during the attempt are generating such lift including but not limited to hills, tree lines, vehicles and hand held devices.

2.2.14 Repeated Record Improvements on One-and-the-Same Day.

On any date that a record is broken by more than one claimant, or repeatedly by the same claimant and model aircraft, the best performance only will be awarded the new record.

2.2.15. Safety

All safety precautions and instructions of paragraph B.19 are applicable to record attempts

2.2.16 Competition Timing

In situations where records are claimed for flights made during the course of Championship competition, it may not be possible for the claimant to determine the specific stopwatches or timing device employed for recording the flight, or the claimant may not have access to the device for calibration purposes. In such cases, the Jury shall, to the best of its ability, attest to the accuracy of the devices.

2.3. SPECIAL RULES FOR DURATION RECORDS

2.3.1. Recording the Time:

1. For all powered sub-classes the flying time starts at the moment when the model aircraft is released.
2. For model aircraft rising off the ground or water, the model aircraft must become airborne in a period that does not exceed 2% of the total flight time.
3. For all gliders, the timing starts when the glider is released from its launching device, or after hand launching.
4. For radio controlled model aircraft with piston engines or electric motors, the engine must be turning the propeller (fully unfolded if a folding propeller is fitted) for at least 98% of the time claimed as a record.

2.3.2. End of Flight:

The flight ends when the model aircraft touches the ground or water or encounters an obstacle which definitely terminates its flight, or when it definitely disappears from the sight of the timekeepers, or from the sight of any devices being used by the timekeepers to track the model. The use of optical devices, electronic devices and other means of proving the model remained airborne is permitted if approved by the National Airsports Control.

For radio controlled models, the point of landing must be within a distance of 500 metres of the point at which the model was released from the ground during the launch.

In the case of a simultaneous record attempt for distance in a straight line and duration, the landing must be within 500 metres of the indicated landing point for the distance record.

2.3.3. Timekeeping:

In the event the time is taken by using electronic stopwatches, two timekeepers must be used. The times registered must be recorded at the scene of the record, and must be signed by the officiating timekeepers. Only these times will be officially recognised. To follow the model in flight, the timekeepers are permitted to move by any means of locomotion available to them

Recording barographs or electronic means of recording time other than stopwatches may be used if they have received prior approval by the organising National Airsports Control. In such cases the time which is established is that recorded by the barograph or electronic device. The loss of altitude between the starting and landing points must not exceed 2 metres for each minute of flying time.

2.3.4. Accuracy of Measurement:

In the case of the use of stopwatches, a synchronous electric clock may be used as a standard of calibration. When other electronic forms of measurement are used, commercial or governmental means may be employed for certification..

Fractions of a second will not be retained in a time registered for a record flight.

2.3.5. Competition Records in Free Flight:

Competition records are recognised for free flight models in competitions which have been registered on the FAI Sporting Calendar. All types of international contests are eligible: Open International, Limited International, Continental Championships, World Championships.

In competition, records are recognised for the following duration in classes F1D and F1L:

- i) the longest duration single flight;
- ii) the longest total of the two best flights (as used for F1D and F1L classification).

For the purposes of Free Flight competition records, the National Airsports Control of the claimant is responsible for lodging the record claim. The claim must be supported by data from the competition. The supporting documentation must include copies of the flight cards recorded at the competition and signed by the timekeepers of the flights. The director of the competition must certify that these records are authentic and certify that the model aircraft used in the record were processed in accordance with the Sporting Code.

For indoor competition records, there is no subdivision according to ceiling categories.

2.4. SPECIAL RULES FOR DISTANCE RECORDS IN A STRAIGHT LINE

2.4.1. There are two possibilities of setting a distance record in a straight line:

- a) Distance from A to B; and
- b) Goal and Return, that is, from A to B and back to A.

2.4.2. Measurement of Distance

The distance of the record shall be that measured in a straight line between the point of departure and landing, whatever may have been the actual path of the model aircraft.

cont/...

In the case of Goal and Return record, the record distance is the distance from the starting point to turning point plus that from turning point to the landing point.

Distances up to 50 kilometres may be measured on an official map of a scale at least 1:100.000.

Distances up to 500 km may be measured on an official map at least 1:200.000 in Gauss/Krieger system.

Distances greater than 500 kms shall be calculated from the earth model WGS84 ellipsoid. The exact position of the take-off point, landing point and turning point may be determined by GPS. For further details, refer to the Sporting Code General Section 7.3.1.1

The dossier claiming the record must contain a detailed calculation, made by a recognised scientific body, of the distance, with reference to the geographical ordinates of the place of departure and arrival.

The degree of accuracy of the measurement must be stated in the dossier.

The distance shall be calculated to an accuracy of at least 1% for distances up to 500 km and 0.5% for distances in excess of 500 km.

2.4.3. Point of Departure:

For powered model aircraft the point of departure is the place where the model aircraft was released. For models rising off the ground or water, the distance covered in take-off cannot exceed 2,0% of the total record claimed.

For gliders, the point of departure is the place where the claimant is at the time when the glider is released from the launching device.

2.4.4. Point of Landing as Defined in 2.2.8.

For radio controlled model aircraft, the pilot must indicate in writing before the flight the place where his model aircraft will land. The actual point of landing must be within a radius of 500 m of the point indicated.

2.4.5. For radio controlled model aircraft, the pilot may follow the model aircraft with his transmitter by any means of transport, the official observers accompanying him.

2.4.6. Turning Point

In the case of Goal and Return distance records, the turning point must be as specified for the landing point in Rule 2.4.4. and the official observers must certify that the turning point has been properly rounded.

2.5. SPECIAL RULES FOR SPEED RECORDS IN A STRAIGHT LINE

2.5.1. Base:

For model aircraft of the Free Flight sub-classes, the record is measured over a base of 50 m for model aircraft with elastic type motors and of 100 m for model aircraft with piston type motors.

The course must be flown in both directions within 30 minutes.

For radio controlled model aircraft the base must be 200 m, and it must be traversed in both directions without any intermediate landing.

The altitude of the model aircraft must remain below 35 m and above 5 m during the 100 m entry and 200 m course. These altitudes are measured from the point where the pilot is standing.

The dossier of the record must include a certified measurement of the course and a statement of the methods used to determine altitude and speed.

For radio control speed record attempts the model aircraft must be fitted with a throttle or any other device to stop the motor by radio control.

cont/...

2.5.2. Timing:

The timing of speed records must be accomplished by timing instruments approved by the organising National Airports Control. If electronic stopwatches are used, timekeeping must be effected by two timekeepers, utilising devices which register to at least 1/100 of a second. The difference between the times registered by the two timekeepers must not exceed 0.05 second. Automatic and other electronic timing devices which register a single time are allowed, provided the system is properly documented in the dossier and approved by the NAC of the claimant(s).

For speeds above 300km/h, manual activation of timing devices is not permitted. Only automatic means of timing which eliminate human error factors are permitted and must be certified accurate within 1/100 of a second.

The mean of the two speeds of the two runs over the timing base gives the record speed.

2.6. SPECIAL RULES FOR SPEED RECORDS IN A CLOSED CIRCUIT

2.6.1. Base:

The course consists of a square, defined by four prominently coloured pylons set 200 m apart on a 90° angle to each other, situated on flat land, or land with a maximum fall not to exceed 1 metre in 200 m within 1 km of the course. Each pylon shall be consecutively numbered one through four. Using a line between Pylon One and Pylon Two as a base line, set Pylon Five (or a wire sighting device) midway between them (i.e. 100 m from each pole). At an angle of 90 degrees to the Base Line set Pylon Six 20 m distant from the Base Line. Place a 10 mm wide reflective (contrasting) strip of tape between Pylon Five and Six as the Start/Finish line.

Note: It is essential for accurate speed measurement that all pylons be absolutely vertical in order to prevent course length differences with altitude.

R/C gliders must be free of the launching cable (specified in 2.2.7.) prior to crossing the Start/Finish line. Models which land prior to completion of all four legs of the course, or intrude into the forbidden airspace (except after timing is completed) are disqualified and the flight void. There is no altitude restriction or prohibition against circling in thermals outside the course.

2.6.2. Timing:

The timing of speed records must be effected by timing instruments approved by the National Airports Control.

Timing begins when the model aircraft crosses the Start/Finish line and ends when the model aircraft completes the course and again crosses the Start/Finish line still airborne within 30 minutes from launch.

Timekeeping must be effected by two timekeepers equipped with timepieces timing to at least 1/100 of a second. The difference between the times registered by the two timekeepers must not exceed 1/50 of a second.

Four judges will be situated immediately under each pylon and will raise a red flag when the model aircraft infringes the space bounded by the poles.

The pilot, his helper, timekeepers and the timing equipment must be located and remain during the record attempts inside the course at Pylon Five. Each pylon judge, also inside the course, will signal with a light when the nose of the model aircraft has passed the sighting device.

Each pilot may have one (1) helper who may launch or release the model aircraft for take-off and keep the pilot informed of the position of his model aircraft during the record attempt.

2.6.3. RC Pylon Race Time Record (10 laps):

Time records in pylon racing can be set over a ten lap course provided the record performance is achieved during a race under normal contest conditions in a World or Continental Championship. The record figure will be the time recorded for completing the appropriate course.

2.7. SPECIAL RULES FOR SPEED RECORDS IN CIRCULAR FLIGHT

2.7.1. The speed will be timed over a minimum distance of one kilometre. Minimum flight circles must be:

Sub-class 130: Swept volume of motor 0 to 1,0 cm³ inclusive. R = 13,27 m (12 laps = 1 km)

Sub-class 131: Swept volume of motor 1,01 to 2,5 cm³ inclusive. R = 15,92 m (10 laps = 1 km)

Sub-class 132: Swept volume of motor 2,51 to 5 cm³ inclusive. R = 15,92 m (10 laps = 1 km)

Sub-class 133: Swept volume of motor 5,01 to 10 cm³ inclusive. R = 19,90 m (8 laps = 1 km)

Sub-class 134: Swept volume of motor 1,01 to 2,5 cm³ inclusive. R = 17,69 m (9 laps = 1 km)

Sub-class 135: Jet reaction motors. R = 19,90 m (8 laps = 1 km)

Note: Longer lines may be used providing that the distance of one kilometre is made up by a whole number of laps except for competition class 134.

2.7.2. Control Line(s):

For record attempts there shall be no limit to the diameter of the control line(s) or restrictions on the construction of the control line(s). This does not apply to competition classes F2 (sub-class 134) or F2C (sub-class 136 and 137).

2.7.3. Fuel:

There shall be no restriction to the composition of the fuel except in competition class 134.

2.7.4. Timekeeping:

The timing must be carried out by two timekeepers using stop watches or an electronic timing apparatus registering to at least 1/100th of a second.

The difference between the two recorded times must not exceed 12/100th of a second.

The timing commences officially when the competitor has placed his handle in the pylon fork and the model, having made 2 complete circuits again passes the height marker on the edge of the circuit directly opposite the timekeepers.

The handle and pylon must conform to the specifications for control line speed contests except that in the case of single line control the competitor may use any handle with a single flexible point of attachment on the control handle and a horizontal bar (handle pivot) as for two line handles, with a 6 mm maximum distance between the flexible point of attachment and the point of contact on the horizontal bar on the pylon fork.

Also for single line control systems, no rigid reinforcement of the line in front of the handle shall be permitted and any torsional, geared or other control mechanism must be positioned behind the pylon fork.

During the whole of the timed portion of the flight, the horizontal bar must rest in the pivoted fork.

All physical effort for the purpose of increasing the speed of the model during a record attempt is forbidden and will entail immediate cancellation.

2.7.5. Height of Flight:

The normal flying height must be between 1 and 3 metres.

2.7.6. Accuracy of Measurement:

The speed recorded will be in kilometres per hour rounded to the nearest lower 1/10th of a kilometre.

2.7.7. Team Race, (Race Time) Records Over 100 laps (sub-class 136) and 200 Laps (sub-class 137) (10 and 20 km):

Race time records in team race can be set over a 10 km (100 laps) course (normal race or semi-final) or a 20 km (200 laps) course (final) provided the record performance is achieved during a race under normal contest conditions in a World Championship or Continental Championship. The record figure will be the time recorded for completing the appropriate course.

2.8. SPECIAL RULES FOR ALTITUDE RECORDS

2.8.1. Verification of Measurements:

In order to establish the height above the starting point it is required:

- a) either to use small barographs made especially for model aircraft and carried on board; the barographs having previously been approved by the National Airsports Control.
- b) or, to ensure control by qualified observers using theodolites or telemeters, provided these instruments have been previously approved by the National Airsports Control.
- c) or, by means of a barograph carried in an aircraft which follows the model but never exceeds the maximum altitude of the model. An official observer must be present in the aircraft during the flight, and the barograph record must be counter signed by the official observer and the pilot of the aircraft.
- d) or by means of an electronic device carried on board the model aircraft and designed to register altitude and record the readings either in graph or digital format. Any such electronic device must be calibrated prior to the attempt and the calibration certificate included in the record claim dossier.

If theodolites or telemeters are used, the National Airsports Control:

- e) Must give a description of the instruments and the methods employed in using them, a signed statement certifying the degree of accuracy reached and a check report on the instruments and the method used.
- f) In the case of a barograph, the calibration must be performed against an absolute pressure gauge and the International Civil Aeronautics Organisation Pressure vs. Altitude Tables may then be used to compute altitude.

2.8.2. Point of Landing:

For radio controlled models, the landing must occur within a radius of 500 metres of the point of departure as described in 2.3.2. In the case of simultaneous attempts for distance and altitude, the landing must be made as described in 2.4.4.

2.9. SPECIAL RULES FOR DISTANCE IN CLOSED CIRCUIT RECORDS

2.9.1. For radio controlled models, the length of the circuit must be over a straight base of 500 m for piston/electro type motor models, and over a base of 100 m for gliders.

2.9.2. Fractions of a circuit will not be included in the record claimed.

2.10. DOSSIER OF A RECORD ATTEMPT

It is the purpose of homologation procedures and requirements to ascertain as well as possible, that a given model aircraft indeed attains the flight performance claimed and that the flight was made within the requirements and standards of this Sporting Code. The many factors involved in the flight require that adequate data be submitted to confirm a record attempt. In unusual circumstances, FAI may request additional substantiating data to insure that these purposes have been achieved.

2.10.1. A dossier must be submitted to the FAI within 120 days of the Record Attempt. It shall include:

- a) A completed official form as shown in Table II.
- b) A three view drawing of the model aircraft showing all basic dimensions and stating the scale of the drawing. Certification countersignature of the National Airsports Control official is required.
- c) A photograph of the model aircraft. Certification countersignature by a National Airsports Control official is required.
- d) Certification that the record has been recognised as a national record by the claimant's NAC.
- e) A statement of supporting data as listed in 2.11 below.
- f) A properly filled out Table III, Record Dossier Check Form.

cont/...

2.10.2. Photocopies of record dossiers are available, upon written request of a National Airports Control, at a fee of 40 Euro for dossiers up to 10 pages and 5 Euro for each additional page.

2.11. SUPPORTING DATA:

Whenever numerical limits are established for special categories, such as 2.3.2. for point of landing, duration of motor run, or as 2.4.3. for take-off run a measurement of these specific quantities should be stated in the supporting data section.

If barographs, special electronic devices, timing equipment, etc., are employed, a description adequate to ascertain the accuracy and validity of the devices must be included.

A statement must be made that all requirements for the specific categories were met.

Latitude and longitude of take-off and landing points, as well as mathematical calculations must be shown for records involving great circle distances.

A listing of all officials and participating observers shall be included. The supporting data sheet shall be signed by the directing official.

For historical purposes, a brief description of the flight is desired. Pertinent factors, such as weather, special equipment in the models or on the ground, or any unusual circumstances occurring during the flight will be of value. This section is not officially required but officials are encouraged to submit it on a separate sheet of paper for future reference.

For Duration and Distance in Closed Circuit records for powered model aircraft (any power source), a statement must be made which shows beyond reasonable doubt that the requirements of paragraph 2.2.13 Flying Site have been met. Documentation such as photographs, maps, and weather observations may be part of such statement.

a) TIME-KEEPING 2.3.3 (Duration) 2.5.2. and 2.6.2. (Speed)

Describe in brief, the method of timekeeping employed.

No. of watches

Position of timekeepers

Electronic equipment used

b) BASE 2.4.1. (Distance) 2.5.1. (Speed) 2.6.1. and 2.9.1. (Closed Circuit)

Describe in brief, the method of establishing the base measurement.

Measuring equipment

Method of marking base limits

Number of observers at base limits

Method of signalling, base to pilot

Supply a sketch of the course, defining base, turning points, marker poles, altitudes of base limits and position of officials relative to course.

ALL REQUIREMENTS OF ARTICLES 2.4.2, 2.8.1, 2.11 MUST ALSO BE OBSERVED AND RECORDED IN THE DOSSIER.

TABLE I

CLASSIFICATION OF RECORDS

PAGE 1 OF 2

SUB CLASS		CATEGORY (Type of model aircraft)	GROUP (Method of propulsion)	TYPE				
				Duration	Distance in a straight line	Gain in altitude	Speed	
F1 FREE FLIGHT	Open	Glider	n/a	101	102	103	n/a	
		Aeroplane	Extensible Motor	104	105	106	107	
	Piston Motor		108	109	110	111		
	Open	Indoor Aeroplane	Extensible Motor	DURATION				
				Ceiling Cat I <8M (a)	Ceiling Cat II 8-<15M (b)	Ceiling Cat III 15-<30M (c)	Ceiling Cat IV >30M (d)	
				115 (a)	115 (b)	115 (c)	115 (d)	
				125 (a)	125 (b)	125 (c)	125 (d)	
				116 (a)	116 (b)	116 (c)	116 (d)	
				117 (a)	117 (b)	117 (c)	117 (d)	
				118 (a)	118 (b)	118 (c)	118 (d)	
	F1N	Indoor Glider	n/a	118 (a)	118 (b)	118 (c)	118 (d)	
	Open	Indoor Aeroplane	Extensible Motor	DURATION IN COMPETITION				
				One Flight		Two Flights		
				119		120		
F1L			122		123			
F2 CONTROL LINE CIRCULAR FLIGHT	Open	Aeroplane	Piston Motor	SPEED				
				SWEPT VOLUME cm ³				
				0,00 to 1,00	1,01 to 2,50	2,51 to 5,00	5,01 to 10,00	
	130			131	132	133		
	F2A			Speed in Competition				
				134*				
Open		Reaction Motor	135					
			TEAM RACE (Race Time)					
F2C			Piston Motor		100 laps - 136*		200 laps - 137*	

* Only in World Championships & Continental Championships.
Reference paragraph 2.1.4.

CLASSIFICATION OF RECORDS

PAGE 2 OF 2

SUB CLASS		CATEGORY (Type of model aircraft)	GROUP (Method of propulsion)	TYPE						
				Duration	Distance in a straight line	Gain in altitude	Distance Goal and return	Speed	Distance in a closed circuit	Speed in a closed circuit
F3 RADIO CONTROL FLIGHT	Open	Aeroplane	Piston Motor	141	142	143	144	145	146	147
		Seaplane		148	149	150	151	152	153	154
		Glider	n/a	155	156	157	158	159	160	161
		Helicopter	Piston Motor	162	163	164	165	166	167	168
	F3D	Aeroplane		In Competition – 10 laps						
F5 RADIO CONTROL FLIGHT	Open	Aeroplane	Electric Motor S	171	172	173	174	175	176	177
			Electric Motor SOL	185	186	187	188	189	190	191
			Electric Motor COMB	192	193	194	195	196	197	198
		Helicopter	Electric Motor	199	200	201	202	203	204	205
	F5D	Aeroplane		In Competition – 10 laps						

* Only in World Championships & Continental Championships.
Reference paragraph 2.1.4.

TABLE II
APPLICATION FOR RECORD ATTEMPT CONFIRMATION
MODEL AIRCRAFT

1. Sub-Class: _____ Category: _____

2. Group (Propulsion): _____ Type (numerical): _____

----- (All from Table I, Part Two of the FAI Sporting Code) -----

3. Record figure claimed: _____ 3. Date of record attempt: _____

4. Name(s) of claimant(s): _____

5. Course/Place: _____

6. FAI Sporting License No(s): _____

7. Nationality: _____

8. Name of NAC: _____

9. Characteristics of Model Aircraft:

Principal Dimensions (Metric Units): Span _____ Length _____ Height _____

Total surface area _____ dm²

Weight: Without fuel _____ With fuel _____

Loading: Minimum _____ Maximum _____

Motor:

Electric motors:

Bore _____

Make/type _____

Stroke _____

Nominal capacity _____ VA

Swept volume _____

Power source(s) S SOL COMB Encircle which is applicable

Make _____

Type of cells _____

No. of cells S: _____ SOL: _____

No of sources of current - COMB: _____

Type of sources of current - COMB: _____

Total working voltage: _____ V

10. I/we, the undersigned, certify that all requirements of the Sporting Code for this category have been met to the best degree that I/we can determine.

Signature of Directing Official

Signature(s) of Claimant(s)

Certification by NAC Official

11. Enclosures:

a) three view drawing

b) photograph of the model aircraft

c) statement of all necessary supporting data

✓ for enclosed documents



Official Stamp of NAC

TABLE III

CHECKLIST RECORD DOSSIER – MODEL AIRCRAFT

When preparing a world record dossier, please check against the list that all requirements have been met.

In the "Check Mark" column, mark ✓ when OK and mark – if not applicable

ITEM No.	DESCRIPTION	CHECK MARK
	GENERAL	
	FAI Office in Lausanne notified by email or fax within seven (7) days of the day the record was set.	
1	Table II completely filled out and properly signed (names also in block letters). Remember certification by NAC official.	
2	Three-view drawing of model, certified by NAC Official (2.10.1.b).	
3	Photograph of model, certified by NAC Official (2.10.1.c).	
4	List of officials and observers, signed by Directing Official (2.11)	
5	Summary of all supporting data submitted with the dossier (2.10.1.e).	
6	All supporting data signed by Directing Official (2.11).	
7	Description of record attempt (2.11).	
7a	Claimant is the builder of the model (if applicable, see 2.1.3).	
7b	Claimant(s) confirm that the aircraft is intended to be a model (1.1).	
7c	Claimant's NAC to confirm the claim as a national record (2.10.1.d).	
8	For RC records a statement confirming that the model was in the sight of the pilot who was in direct radio control of the model aircraft via a transmitter, for the whole of the flight.	
8a	For F5 COMB records, claimants must provide authenticated evidence for each of the minimum two power sources.	
9	DURATION RECORDS	
	Flight card, showing both stopwatch readings entered in ink, signed by both time-keepers (2.3.3).	
9a	Final record figure rounded off to lower whole second, discarding fractions of a second (2.3.4).	
9b	Certificate on accuracy of stopwatches (2.3.4) or special timing devices (2.11).	
9c	Statement that duration of take-off run of hydroplane does not exceed 2% of total flight time (2.3.1.2).	
9d	Statement that duration of engine run of RC models is not less than 98% of total flight time (2.3.1.4).	
9e	Statement on landing point for RC models (2.3.2).	
9f	Statement on flying site required for powered models (2.2.13).	
10	DISTANCE RECORDS IN STRAIGHT LINE	
	Official map showing record distance, take-off and landing points (2.4.2) (or WGS84 software calculation): at least scale 1:100.000 for distances up to 50 kms; at least scale 1:200.000 in Gauss-Krieger system for distances from 50 to 500 km. WGS84 software calculation for distances greater than 500 km. (2.4.2).	
10a	Geographic coordinates of take-off and landing point (2.4.1 and 2.11).	
10b	Calculation of record distance by Geographic Scientific Body including statement on degree of accuracy of the calculation (2.4.2) signed by the Directing Officials.	
10c	Statement of actual landing point with reference to point of landing made in writing before start of record attempt (2.4.4).	
11	SPEED RECORDS IN STRAIGHT LINE (Free Flight and Radio Controlled)	
	Flight card with both stopwatch readings of each of the two flights required (2.5.2) or the time recorded thereof by an electronic timing device (B.8.9), signed by the time-keepers and the Directing Official.	
11a	Certificate on measuring of the speed course (2.5.1 and 2.11).	
11b	Statement on method used to determine altitude and speed (2.5.1).	
12	SPEED RECORDS IN CLOSED CIRCUIT	
	Flight card with both stopwatch readings of the record flight, or the time recorded thereof by an electronic timing device (B.8.9), signed by both time-keepers and the Directing Official (2.6.2).	
12a	Description and sketch of arrangement of the course (2.11b)	
12b	Statement on measurement of the base (2.6.1).	
13	ALTITUDE RECORDS	
	Barograph record signed by Directing Official (2.8.1).	
13a	If model has been followed by full size aircraft, barograph record should be countersigned by both the pilot and official observer (2.8.1)	
13b	Barograph calibration record or calibration table (2.8.1).	
13c	If theodolites were used, readings should be recorded and calculations of height must be submitted, signed by official observer (2.8.1).	
13d	Description of special equipment used, include a signed statement on accuracy and calibration certificate for any electronic device used to record altitude (2.8.1).	
13e	Statement on landing point for RC models (2.8.2).	
14	SPEED RECORDS IN CIRCULAR FLIGHT (Control Line)	
	Flight card with both stopwatch readings or the time recorded thereof by an electronic timing device (B.8.9), signed by the time-keepers and Directing Officials.	
14a	Statement that line length is in accordance with the requirements of 2.7.1.	
15	DISTANCE RECORDS IN CLOSED CIRCUIT	
	Description and sketch of arrangement of course (2.9.1).	
15a	Statement on measurement of base (2.9.1).	
15b	Statement on flying site required for powered models (2.2.13)	

PAGE DELIBERATELY LEFT BLANK