

ANNEX 4F

CLASS F2E - COMBAT MODELS WITH COMPRESSION IGNITION ENGINES

4.F.1. Definition of a Combat Event

A combat event is a contest during which eliminating heats are followed by a final in which two competitors with their model aircraft fly in the same circle at the same moment for a predetermined time, the object being to cut a streamer attached on the longitudinal centre line of the opponent's model aircraft, points being awarded for each cut taken.

4.F.2. Definition of a Combat Model Aircraft

- a) Model aircraft in which the propulsion energy is provided by a piston motor and in which lift is obtained by aerodynamic forces acting on surfaces which remain fixed in flight, except for control surfaces.
- b) The longitudinal centre line shall be defined as the axis of the propeller.

4.F.3. Combat Site

A combat site must consist of three concentric circles which shall be marked on the ground.

- a) The pilot circle: radius 2 metres.
- b) The flight circle: radius 20 metres
- c) The pitting circle: radius 22 metres

The flight and pitting circles must be laid out on grass. The pilot circle may be laid out on grass or any other material. The area between the 20 and 22 metre circles is called the pitting area.

During active combat periods the pilot and his mechanic(s), officials, team managers and others within the boundary of the flying site must wear a safety helmet, with a fastened chinstrap, strong enough to withstand the impact of a flying combat model aircraft.

4.F.4. Competitor

The pilot, who shall be the entrant and known as the competitor, may employ a maximum of two mechanics in any one heat. (In exceptional circumstances of wet or extremely windy weather, an additional helper may be used as a streamer holder and must perform no other function for the duration of that combat period).

For World and Continental Championships, the mechanics, a maximum of six other than team members or the team manager (or assistant team manager), must be registered for no more than one national team, from the beginning of the competition throughout to the end.

To avoid the catching of the opponent's lines the protruding parts of the helmet must be covered. No Communication using electronic devices is allowed between the pilot and mechanics/persons outside the flying circle.

4.F.5. Characteristics

- a) Maximum loading: 100 g/dm²
Maximum swept volume of motor: 2,5 cm³
Motor type: Compression ignition
- b) Line length: 15,92 +/- 0,04 m
Minimum line diameter: 0,385 mm (no minus tolerance)
Two multi-strand control lines must be used. No free ends capable of entangling an opponent's lines, and no line splices, are permitted. Open connection connectors are not allowed.
- c) The motor must run on a suction fuel feed only, with the fuel tank mounted such that the entire fuel tank is outboard of the longitudinal centre line.
- d) The motor shall be naturally aspirated via a single round venturi with a maximum effective diameter of 3,5 mm.
- e) Any interconnecting chamber between the air intake and the induction port of the motor shall have a maximum volume of 1,75 cm³. This clearly prohibits sub-piston induction for supplementary air intake.
- f) A safety wire with a minimum diameter of 0,5 mm must be attached between the control system and the engine. The engine must always stay connected to the lines.

- g) A safety strap connecting the competitor's wrist to the control handle must be provided by the competitor and worn at all times while his model aircraft is flying. The strap should be as shown in the sketch i.e. it should be attached to the wrist with a loop and sliding knot so that if the handle is released it will tighten itself securely around the wrist. The point of attachment at the handle is up to the discretion of the pilot.

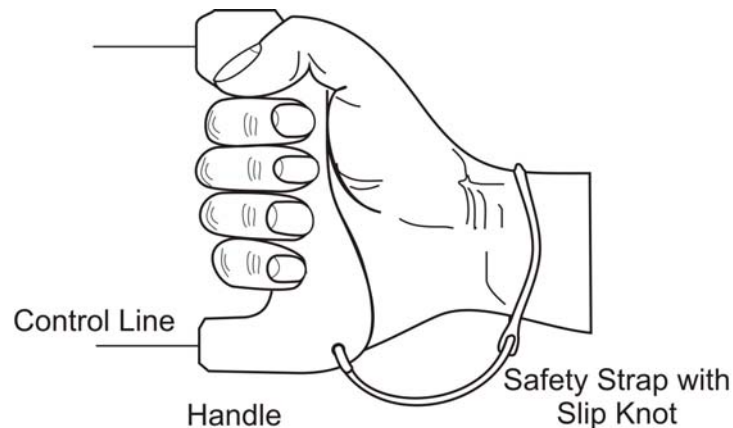

- h) The model aircraft shall not carry any artificial aid to assist the cutting of the streamers.
i) The model aircraft shall be equipped with a device specially designed to retain the streamer which shall be fitted on the longitudinal centre line and sufficiently strong so that the streamer shall not become detached under normal flying conditions.
j) Fuel is not restricted.
k) The propeller must be of 190 mm minimum diameter and 150 mm minimum pitch from a blade radius of 40 mm to the tip and constructed from a thermoplastic material (glass filling is allowed).

Note: Rule B.3.1. Section 4B, Sporting Code Volume ABR, does not apply to class F2E.

4.F.6. Technical Verification

To be tested before each heat:

- a) The set of lines must be checked for length and diameter.
The line length is measured from the inboard face of the grip of control handle to the longitudinal centre line of the model aircraft.
A pull test shall be applied to the assembled handle, control lines and model aircraft. The pull test shall be equal to 150 N.
The processing officials or judges may ask the competitor to change the lines if there is any doubt about the line quality, such as kinks, curls, stress or rubbing marks.
- b) The intake opening shall be checked with a simple plug gauge of diameter 3,55 mm.
- c) The safety strap and safety wire may be pull tested with a load equal to 150 N.

4.F.7. Number of Model Aircraft

- a) Only one model aircraft specification certificate is required for each design of model aircraft presented by each competitor.
- b) Each competitor shall be permitted one model aircraft, one handle, one pair of lines and one engine in each combat heat.

4.F.8 Streamer

The streamer shall consist of double weight crepe paper (80 g/m^2) or any replacement of equivalent strength, not less than 2,25 m or more than 3 m long and $3 \pm 0,5$ cm wide, fixed to a sisal (or any replacement of equivalent strength) string of 3,25 m minimum length. All streamers must be of the same length. There shall be a clearly visible ink mark 2,5 m from the junction of the string and streamer. The streamer shall be attached to the model aircraft in such a way that the ink mark is level with, or behind, the rearmost portion of the model aircraft (see sketch). The attachment part of the string shall have a minimum length of 0,75 m. The attachment end of the streamer shall be reinforced on either side by tape approximately 2 cm wide affixed diagonally to the length of the streamer with one at right angles to the other and extending for a maximum of 5 cm. An additional fibre/fabric reinforced tape 2 cm wide is affixed across the streamer (see detail below).

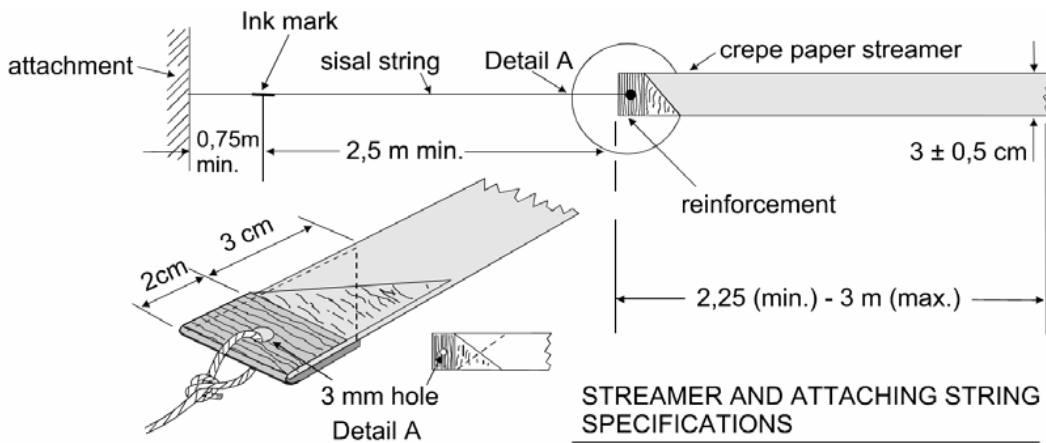

The colour of the streamer must be different for the two competitors in the heat. Each pilot/pit crew shall be issued with a streamer before the start of the heat by the judge assigned to that competitor. A new streamer will be available from the judges when needed.

4.F.9. The Heat from start to finish

- a) All signals shall be both acoustic and visual.
- b) During the starting period the launching positions must be separated by at least a quarter of a lap. The first named competitor in the draw shall have the choice of streamer colour and the other the choice of starting position.
- c) It is the responsibility of the pilot/mechanics to make sure the streamer is unrolled before take-off.
- d) The motor must be started by flicking the propeller by hand.
- e) A first signal, given by the Official Timer, shall signify the beginning of the 60 seconds period when the mechanic(s) or the pilot have the opportunity to start, run and adjust their motor.
- f) A second signal, given by the Official Timer, shall signify the beginning of the combat heat period on or after which the model aircraft may be launched.
- g) From the moment the Official Timer has given the signal to launch the combat heat lasts for 4 minutes.
- h) When the Circle Marshal is satisfied that each model aircraft has completed two level laps, anti-clockwise, separated by approximately half a lap, he will give a signal that combat may begin.
- i) Following an interruption when one or both model aircraft have been grounded, combat may restart after a signal from the Circle Marshal. This signal shall be given as soon as the Circle Marshal is satisfied that there is approximately half a lap separation between the two model aircraft.
- j) If, after a mid-air collision, no streamer can be found and the streamer retaining device is missing or bent, then, with the permission of the judges, it is acceptable to continue the heat without replacing the streamer.
- k) Models in the pitting area may not be moved, except to open a safe distance (approximately 5 metres) away from the opponent's mechanics. Unless otherwise directed by the judges, it is the rearmost team's responsibility to move back before pitting. Under conditions of heavy wind, the Judges can allow models with a non-running engine to be moved to a safer starting position.
- l) When moving around the circle the mechanics/pilots must be on the outside of the pitting circle. Within the pitting area and flight circle, mechanics may only move radially inward and outward.
- m) The Circle Marshal shall signal both pilots to fly level and anti-clockwise and to cease combat when both streamer strings have been cut.
- n) The Circle Marshal will monitor the conduct of both pilots, and shall issue a yellow card warning to any pilot who uses a rough or unsafe flying style, causes line tangles, or displays unsportsmanlike behavior. Each yellow card issued (a maximum of three for each pilot, per competition) shall be officially recorded and retained for the remainder of the competition. Initial and subsequent offences during a competition are to be penalized in accordance with 4.4.12A and 4.4.12C, respectively. If the first yellow card incident is considered severe, the pilot shall also be disqualified for this offence.
- o) The Circle Marshal shall give an acoustic signal to terminate the combat heat 4 minutes after the signal to launch (10 seconds countdown).
- p) The same acoustic signal shall be given if the contest has to be terminated due to disqualification of one or both contestants or for any other reason.

4.F.10. Scoring

- a) Scoring shall start at the signal to launch and continue during the heat (maximum 4 minutes).
- b) 100 points shall be awarded for each distinct cut off the opponent's streamer. There is a cut each time the model aircraft, propeller or lines fly through the opponent's streamer resulting in particle(s) becoming detached from the streamer. A cut that contains string only does not count.
- c) **Two points** shall be awarded for each second that a model aircraft is airborne during the heat. In the case of a model aircraft fly-away the watches should be stopped from the moment of the fly-away.
- d) Each penalty point given (See 4.4.12) shall be subtracted from the competitor's score.
- e) In the event of a tie score in any heat, that heat shall be re-flown. A heat is considered a tie if the score difference is **10 points** or less.

4.F.11. Reflights

A reflight may be granted:

- a) In the event of a line tangle resulting in the control line(s) breaking and only one model aircraft being grounded, making it impossible to clear the line tangle.
- b) If, as a result of combat, a model aircraft cuts its own streamer/string or the streamer/string becomes wrapped around the model aircraft and/or the lines (unless only string remains).
- c) **at the discretion of the Judges/Circle Marshal if an unfair situation occurs and none of the pilots/mechanics can be blamed.**
- d) In the event of a model fly-away, as a result of the lines being broken by his opponent's model or by a line tangle.

4.F.12. Penalties and disqualifications

A. A competitor will receive a penalty of 40 points:

- a) if he steps outside the pilot circle with one foot while his model aircraft is airborne.
- b) if the mechanics enter the flying circle at an oblique angle or cut across the flying circle to reach a downed model aircraft. One penalty only will be given for each offence even if more than one mechanic is involved.
- c) if the mechanic(s)/pilot do not immediately, or after a clearing a line tangle, withdraw a grounded model aircraft to the pitting area prior to servicing it.
- d) if the model aircraft is launched prior to the starting signal.
- e) **when he receives his first yellow card (Subject to 4.4.9.n.).**

B. A competitor will receive a penalty of 100 points:

- a) **if the streamer does not cleanly unfurl upon launching the model aircraft.**
- b) if the mechanic(s) damage the streamer or allow the model aircraft to cut its own streamer whilst still on the ground, and launch the model without replacing the streamer.
- c) if the string becomes detached from the model aircraft while airborne prior to the signal to start combat.

In all these cases the pilot must immediately on a signal from the Circle Marshal land and unfurl/replace the streamer. The watches should be stopped at the moment the pilot is asked to land.

C. A competitor will be disqualified from the heat:

- a) if he flies with a model that does not conform to 4.F.5.
- b) if his model aircraft fails to become airborne within two minutes of the signal to launch.
- c) if he attempts to fly a model aircraft which at the time of launch does not have a:
 - i) strong effective control mechanism
 - ii) secure engine attachment
- d) if he deliberately attacks the streamer of his opponent's model aircraft prior to the Circle Marshal's signal to start combat.
- e) if he interferes with his opponent, or forces his opponent to leave the pilot circle.
- f) if, while his model is not airborne and his opponent is flying or ready to fly, he leaves any parts of his model or lines in the pilot circle without an immediate attempt to clear them.
- g) if he attacks his opponent's streamer without his own, or the remaining parts, attached to his model aircraft (Except for 4.F.9.j).
- h) if he is not present at his allotted flight time, unless he has the express permission of the Event Director.
- i) if he leaves the pilot circle, intentionally while his model aircraft is flying.
- j) if he leaves the pilot circle without informing his opponent of his intention to do so when his model aircraft is grounded for a purpose other than to allow his model aircraft to be serviced.
- k) if he flies in such a manner as to inhibit his opponent, or his opponent's pit crew, from clearing any line tangle.
- l) if he flies other than level in an anticlockwise direction when only his model aircraft is airborne and there is no line tangle. Sudden or rough manoeuvres are not allowed.

- m) if he releases the handle and the safety strap separates from handle or wrist or removes the safety strap, for any reason, while the model aircraft is flying.
- n) if he interferes to cause a ground hit of, or collides with his opponent's model aircraft that clearly has no streamer left and flies level in anticlockwise direction without any manoeuvres to chase and attack.
- o) if the streamer becomes detached from the streamer retaining device during combat, but not as a result of a mid-air collision.
- p) if the model aircraft lands with no streamer string, unless the streamer retaining device is missing or bent as a result of a mid-air collision.
- q) if, during a line tangle where one or both models remain airborne, his mechanic(s) enters the flying circle.
- r) when he receives his second or third yellow card (Subject to 4.4.9.n.).
- s) for any other flagrant breach of the rules.

4.F.13 The use of Video equipment

The Organiser/Judges may use a video recording equipment to monitor the pilots and the pilot circle. At the discretion of the Judges/Circle Marshal the officially recorded video can be used as a judging tool.

4.F.14 Individual and Team Classification

- a) The contest shall be run as a knockout tournament.
- b) The competitor who obtains the highest score in points shall be the winner of each heat.
- c) A competitor shall be eliminated from the competition when he has lost two heats.
- d) Each round shall be randomly drawn (subject to 4.F.14.e)) from the competitors remaining in the competition.
- e) Previous opponents and competitors of the same nationality shall be drawn apart if possible with competitors of the same nationality to fly against each other only if there are no remaining opponents. Defending champions, not members of their national team, are considered as individuals not possessing any specific nationality.
- f) In a round with an odd number of competitors the non-flying competitor will fly twice in the following round, in the first heat and in the last heat (if the number of competitors permit it and he still is in the contest).
- g) Each competitor shall be ranked according to his number of wins, not counting fly-off heats, with the fly-off heats being used to establish second and third place as necessary.
- h) In the event of a tie for second or third place fly them off allowing only one loss during the fly-off. In the event of a tie for third place after a fly-off for second place do a new fly-off.
- i) A specific junior final tournament will be organised if juniors are at the same placing (tie) in the general tournament, in order to define who is first, second and third for the specific individual placing and will have no influence on the general individual placing (no change in the team classification).
- j) The competitors "win" scores, not counting fly-offs, shall be added for the participants of each nation.
- k) The team classification is established by taking the total scores, obtained in 4.F.14.g) above, of the three best scoring members of the team together. In the case of a team tie, the team with the lower sum of place numbers, given in order from the top, wins. If still equal, the best individual placing decides. Complete three-competitor teams are ranked ahead of two competitor teams which, in turn, are ranked ahead of single competitor entries.

4.F.15. Judges and Timekeepers

- a) The organiser shall appoint a panel of three CIAM approved judges (for Open Internationals needs only one to be CIAM approved) and who shall be of at least two different nationalities. The judges must have at least one language in common.
- b) Two timekeepers/scorers shall be allotted to each competitor.